

UPUTSTVO ZA MONTIRANJE  
ASSEMBLING INSTRUCTION  
MONTAGEANLEITUNG  
INSTRUCTIONS D'ASSEMBLAGE  
INSTRUCCIONES DE MONTAJE

ISTRUZIONI PER L'INSTALLAZIONE  
ИНСТРУКЦИЯ ПО МОНТАЖУ  
MONTÁŽNÍ NÁVOD  
ΟΔΗΓΙΕΣ ΣΥΝΑΡΜΟΛΟΓΗΣΗΣ  
INSTRUCȚIUNI DE MONTAJ

ИНСТРУКЦИЯ ЗА МОНТАЖ  
SZERELÉSI UTASÍTÁS  
NAVODILA ZA MONTAŽO  
UPUTE ZA MONTAŽU  
UPUTSTVO ZA MONTIRANJE

УПАТСТВО ЗА МОНТИРАЊЕ  
UDHËZIMET PËR MONTIM  
INSTRUKCJA MONTAŻU  
INSTRUÇÕES DE MONTAGEM  
MONTAGE INSTRUCTIE

# Kuchyňská linka 200 KATE

\* **RS ME** Naznačeno vreme montaže važi za stručno obučena lica (profesionalne montažere)/**UK** The specified installation time applies to professionally trained persons (professional installers)/**DE AT CH** Die bezeichnete Zeit der Montage gilt für fachlich geschulte Personen (professionelle Monteure) / **FR CH** Le temps d'installation spécifique s'applique aux personnes formées professionnellement (installateurs professionnels) / **ES** El tiempo de instalación especificado se refiere a personas profesionalmente capacitadas (instaladores profesionales) / **IT CH** tempo di installazione indicato vale per le persone professionalmente preparate (installatori professionali) / **RUS** Приведённое время монтажа действительно для специально обученных лиц (профессиональных монтажников) / **CZ** Uvedená doba montáže se vztahuje na odborně způsobilé osoby (profesionální montér) / **EL** Ο αναφερόμενος χρόνος εγκατάστασης ισχύει για εκπαιδευμένα άτομα (επαγγελματίες εγκαταστάτες) / **RO** Timpul de instalare specificat se aplică persoanelor instruite profesional (instalatori profesioniști) / **BG** Посоченото време за монтаж се отнася за професионално обучени лица (професионални монтажници) / **HU** Az összeszerelés megjelölt ideje a szakképzett személyekre vonatkozik (hivatásos összeszerelők) / **SL** Navedeni čas namestitve (montaže) velja za strokovno usposobljene osebe (strokovne monterje) / **HR** Navedeno vrijeme montaže odnosi se na stručno osposobljene osobe (profesionalne montažere) / **BIH** Naznačeno vrijeme montaže važi za stručno obučena lica (profesionalne montažere) / **MK** Naznačeno vreme za montaž važi za stručno obučeni lica (profesionalni montažeri) / **AL** Koha e specifikuar e instalimit zbatohet në rast të personave me trajnim profesional (instalues profesionistë) / **PL** Znacznony czas montażu dotyczy przeszkolonych zawodowo osób (profesjonalnych monterów) / **PT** O tempo de montagem indicado aplica-se a pessoas profissionalmente treinadas (instaladores profissionais) / **NL BE** De aangegeven installatietijd is geldig voor professioneel opgeleide personen (professionele installateurs).

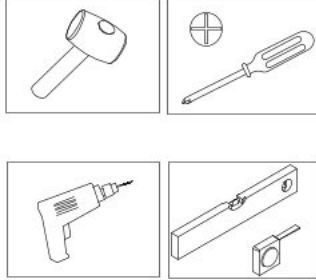
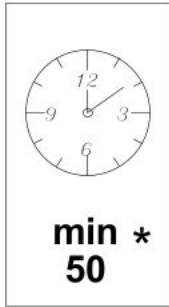
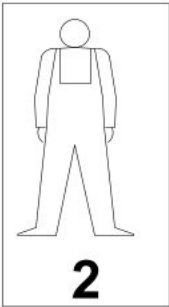

**RS ME** PRE POČETKA MONTIRANJA OBAVEZNO PROČITAJTE UPUTSTVO ZA MONTAŽU / **UK** BEFORE STARTING, REFER TO THE ASSEMBLING ADVICE IN ANNEX / **DE AT CH** VOR DER MONTAGE BITTE BEILIEGENDE ANWEISUNGEN LESEN / **FR CH** AVANT LE DÉBUT DE L'ASSEMBLAGE, S'IL VOUS PLAÎT, LISEZ L'INSTRUCTION D'ASSEMBLAGE / **ES** ANTES DE EMPEZAR EL MONTAJE, LEER CUIDADOSAMENTE LAS INSTRUCCIONES DEL ANEXO / **IT CH** PRIMA DI INIZIARE L'INSTALLAZIONE SI RACCOMANDA DI LEGGERE LE ISTRUZIONI DI INSTALLAZIONE / **RUS** ДО НАЧАЛА МОНТАЖА ОЗНАКОМЬТЕСЬ С ИНСТРУКЦИЕЙ / **CZ** SEZNAMTE SE S NÁVODEM PŘED MONTÁŽÍ NÁBYTKU / **EL** ΠΡΙΝ ΞΕΚΙΝΗΣΕΤΕ ΤΗ ΣΥΝΑΡΜΟΛΟΓΗΣΗ, ΟΠΩΣΔΗΠΟΤΕ ΔΙΑΒΑΣΤΕ ΤΙΣ ΟΔΗΓΙΕΣ ΣΥΝΑΡΜΟΛΟΓΗΣΗΣ / **RO** ÎNAINTE DE ÎNCERPEREA MONTAJULUI ESTE OBLIGATORIE CITIREA INSTRUCȚIUNILOR / **BG** ПРЕДИ МОНТИРАЊЕ НЕ ЗАБРАВЯЙТЕ ДА СЪ ЧЕТЕ ИНСТРУКЦИИ ЗА МОНТАЖ / **HU** SZERELÉS ELŐTT OKVETLENÜL OLVASSA EL A HASZNÁLATI UTASÍTÁST / **SL** PRED ZAČETKOM MONTAŽE OBEZNO PREBERITE NAVODILA / **HR** PRIJE MONTAŽE UPOZNATI SE SA UPUTSTVOM / **BIH** PRE POČETKA MONTIRANJA OBAVEZNO PROČITAJTE UPUTSTVO ZA MONTAŽU / **MK** ПРЕД ПОЧЕТОК НА МОНТИРАЊЕ ЗАДОЛЖИТЕЛНО ДА СЕ ПРОЧИТА УПАТСТВОТО ЗА МОНТИРАЊЕ / **AL** PARA FILLIMIT TË MONTIMIT LEXONI PATJETËR UDHËZIMIN PËR MONTIM / **PL** PRZED ROZPOCZĘCIEM MONTAŻU PROSZĘ ZAPOZNAĆ SIĘ Z INSTRUKCJĄ / **PT** ANTES DE INICIAR A MONTAGEM, CERTIFIQUE-SE DE LER AS INSTRUÇÕES DE MONTAGEM / **NL BE** LEES DE MONTAGE INSTRUCTIE VOORDAT U MET DE INSTALLATIE BEGINT

**V1**

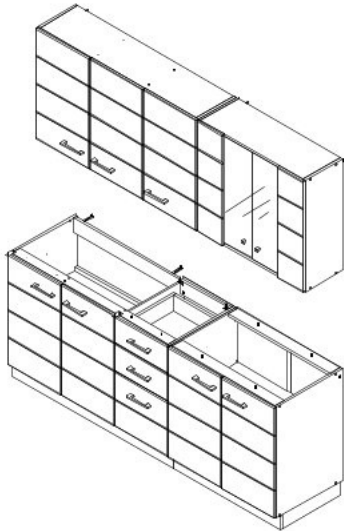

**V2**

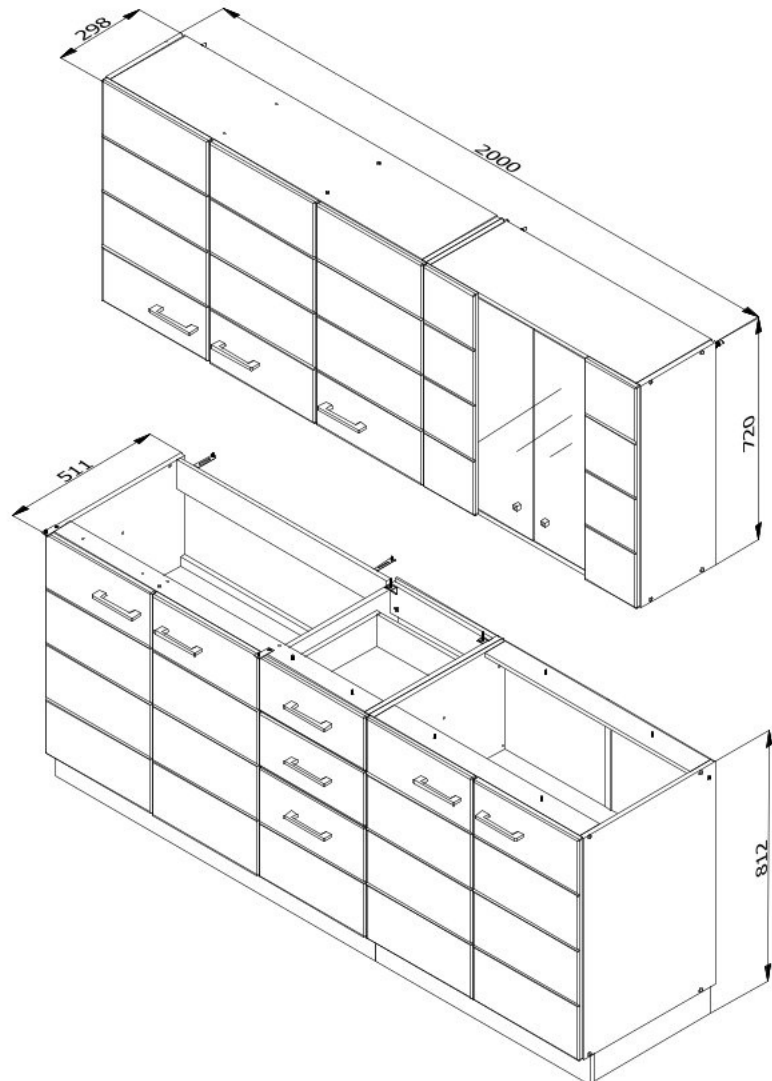
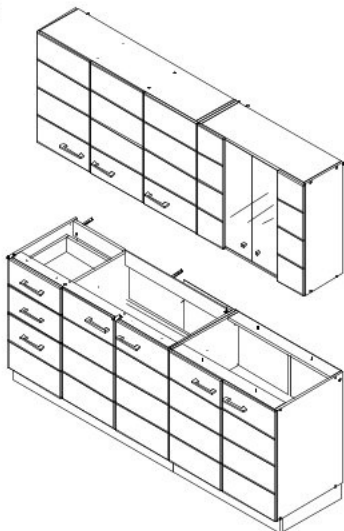

28743	767 mm	440 mm	16 mm	1
28878	312 mm	100 mm	16 mm	2
29013	768 mm	492 mm	16 mm	1
29014	800 mm	92 mm	16 mm	1
29015	718 mm	386 mm	3 mm	1
29016	718 mm	392 mm	3 mm	2
29017	768 mm	76 mm	16 mm	1
29019	768 mm	76 mm	16 mm	1
29022	706 mm	392 mm	3 mm	4
29172	1168 mm	492 mm	16 mm	1
29175	784 mm	94 mm	16 mm	1
29177	783 mm	444 mm	16 mm	1
29178	798 mm	330 mm	3 mm	1
29179	706 mm	400 mm	3 mm	1
29180	1168 mm	66 mm	16 mm	1
29182	440 mm	92 mm	16 mm	2
29291	1200 mm	92 mm	16 mm	1
29841	720 mm	495 mm	16 mm	2

29842	720 mm	495 mm	16 mm	2
29874	716 mm	396 mm	16 mm	7
29875	354 mm	396 mm	16 mm	1
30955	716 mm	194 mm	16 mm	2
31084	784 mm	94 mm	16 mm	1
31085	368 mm	94 mm	16 mm	1
31086	688 mm	492 mm	16 mm	1
31087	720 mm	282 mm	16 mm	4
31088	768 mm	282 mm	16 mm	2
31089	1168 mm	282 mm	16 mm	2
31090	688 mm	279 mm	16 mm	1
31091	767 mm	242 mm	16 mm	4
31092	383 mm	242 mm	16 mm	2
31093	400 mm	100 mm	16 mm	4
31672	396 mm	176 mm	16 mm	2
32368	399 mm	342 mm	3 mm	2
31010820	684 mm	242 mm	4 mm	1
31010821	684 mm	242 mm	4 mm	1

Package 1/4	
29014	1
29015	1
29016	2
29172	1
29175	1
29178	1
29180	1
29182	2
29291	1
29841	2
29842	2
31084	1
31085	1
31093	4

Package 2/4	
28743	1
28878	2
29013	1
29017	1
29019	1
29022	4
29177	1
29179	1
31086	1
32368	2

Package 3/4	
31087	4
31088	2
31089	2
31090	1
31091	4
31092	2

Package 4/4	
29874	7
29875	1
30955	2
31010820	1
31010821	1
31672	2

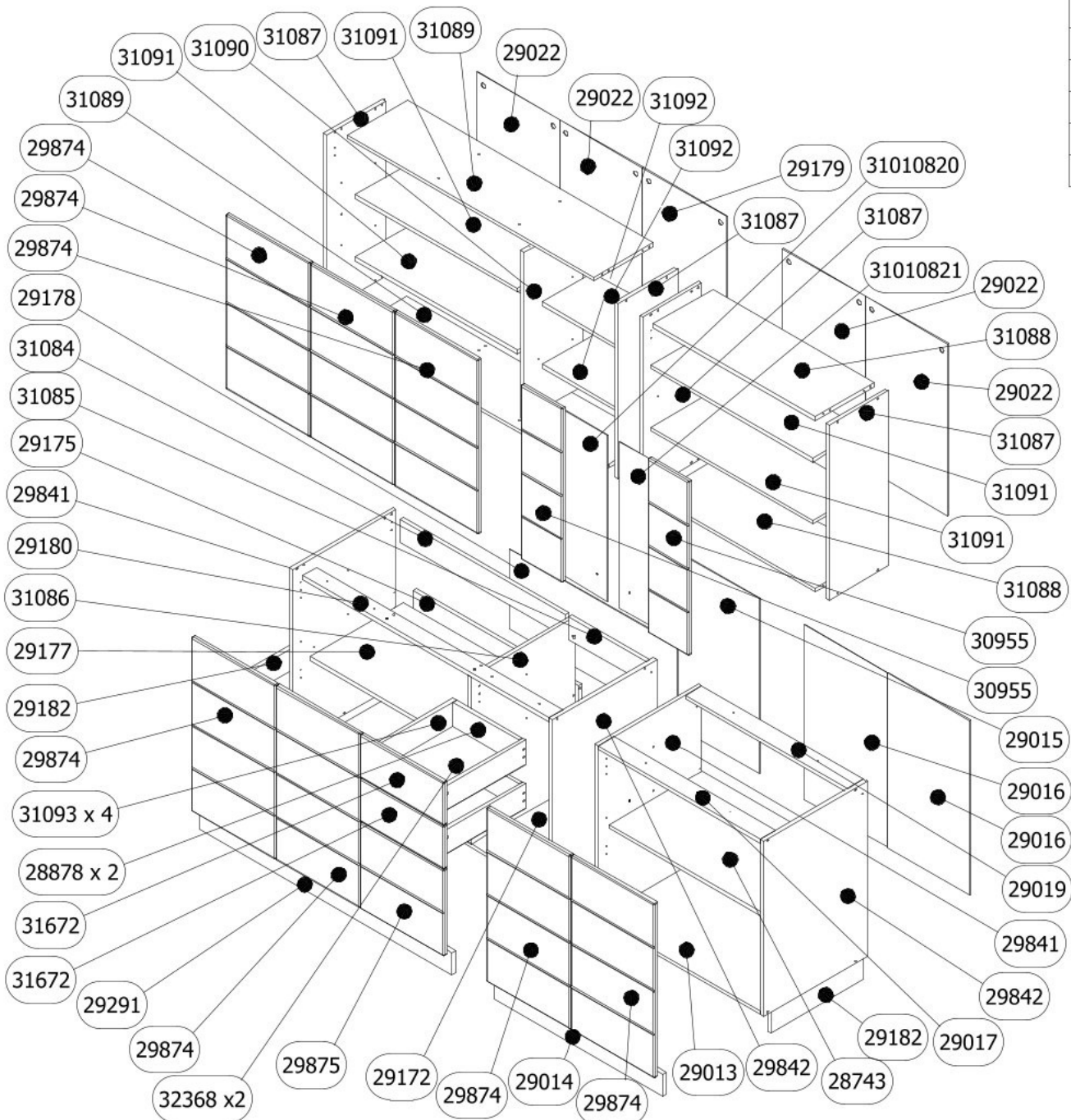

<p><b>RS ME</b></p> <ol style="list-style-type: none"> <li>1. Montažu obavljati na čistoj i mekoj podlozi (karton, tkanina...)</li> <li>2. Da bi izbegli oštećenja elemenata pridržavati se datih instrukcija.</li> <li>3. Prilikom prijave reklamacije koristiti date oznake elemenata.</li> </ol>	<p><b>FR CH</b></p> <ol style="list-style-type: none"> <li>1. Effectuer l'assemblage sur une surface propre et douce (carton, tissu...)</li> <li>2. Afin d'éviter l'endommagement des éléments, respectez les instructions données.</li> <li>3. Lors de l'application de réclamation, utiliser les désignations données des éléments.</li> </ol>
<p><b>DE AT CH</b></p> <ol style="list-style-type: none"> <li>1. Die Montage soll auf sauberer, weicher Fläche durchgeführt werden (Karton, Stoff)</li> <li>2. Um die Beschädigung der Elemente zu vermeiden, befolgen Sie bitte die angegebenen Instruktionen</li> <li>3. Bei Reklamationsmeldungen benutzen Sie bitte die angegebenen Kennzeichen der Elemente</li> </ol>	<p><b>UK</b></p> <ol style="list-style-type: none"> <li>1. Assembly of the product should be done on a clean and soft surface (cardboard, fabric)</li> <li>2. To prevent damage of the product, it is necessary to adhere to the assembly instructions</li> <li>3. While reporting defective products, please quote codes in manual</li> </ol>
<p><b>ES</b></p> <ol style="list-style-type: none"> <li>1. Realizar el montaje sobre una superficie limpia y suave (cartón, paño)</li> <li>2. Para evitar daños del producto, atenerse a las instrucciones de montaje</li> <li>3. Para reportar productos defectuosos, refiérase por favor a los códigos del manual</li> </ol>	<p><b>IT CH</b></p> <ol style="list-style-type: none"> <li>1. Eseguire l'installazione su una base morbida (cartone, tessuto).</li> <li>2. Seguire le istruzioni per evitare di causare danni agli elementi.</li> <li>3. In caso della presentazione di reclamo si utilizzano relative indicazioni degli elementi.</li> </ol>
<p><b>RO</b></p> <ol style="list-style-type: none"> <li>1. Montarea se efectueaza pe o suprafata moale și curată (carton, material...)</li> <li>2. Respectați instrucțiunile pentru a evita deteriorarea pieselor</li> <li>3. La transmiterea reclamațiilor a se folosi inscripțiile date ale pieselor</li> </ol>	<p><b>CZ SK</b></p> <ol style="list-style-type: none"> <li>1. Montáž provádět na čistém a měkkém podkladu (lepenka, látka)</li> <li>2. Dodržujte příložené instrukce, abyste předešli poškození součástí</li> <li>3. Při reklamaci používejte příložené označení element</li> </ol>
<p><b>EL</b></p> <ol style="list-style-type: none"> <li>1. Η συναρμολόγηση του προϊόντος πρέπει να γίνει σε καθαρή και μαλακή επιφάνεια (χαρτόνι, ύφασμα).</li> <li>2. Για να μην φθαρούν τα στοιχεία, συμμορφωθείτε με τις οδηγίες που παρέχονται.</li> <li>3. Κατά τη δήλωση ελαττωματικού προϊόντος, αναφέρετε τους κώδικες των στοιχείων όπως αναφέρονται στο εγχειρίδιο.</li> </ol>	<p><b>RUS BLR</b></p> <ol style="list-style-type: none"> <li>1. Монтаж изделия выполнять на чистой и мягкой поверхности (картон, ткань)</li> <li>2. Для предотвращения порчи изделий необходимо придерживаться правил монтажа</li> <li>3. В случае предъявления претензии использовать данные обозначения элементов.</li> </ol>
<p><b>BG</b></p> <ol style="list-style-type: none"> <li>1. Монтажът трябва да бъде извършен върху чиста и мека основа /karton, тъкан/</li> <li>2. За да избегнете оцетяване на елементи, спазвайте дадените инструкции</li> <li>3. При наличие на рекламация, използвайте дадените кодове на елементи</li> </ol>	<p><b>HU</b></p> <ol style="list-style-type: none"> <li>1. A szerelés tisztaság és puha felületen (karton, anyag) kell végrehajtani.</li> <li>2. Károsodásnak elkerülése érdekében tartsa be a megadott utasításokat.</li> <li>3. Reklamáció esetén hivatkozzon a bútör alkatrészein megadott jelekre.</li> </ol>
<p><b>SL</b></p> <ol style="list-style-type: none"> <li>1. Montažo opravimo na čisti in mehki podlogi (karton, tkanina)</li> <li>2. Da bi se izognili poškodbam elementov, upoštevajte navodila.</li> <li>3. Pri reklamaciji uporabimo oznake elementov</li> </ol>	<p><b>BIH HR</b></p> <ol style="list-style-type: none"> <li>1. Montažu obavljati na čistoj i mekoj podlozi (karton, tkanina)</li> <li>2. Da bi izbjegli oštećenja elemenata pridržavati se datih instrukcija</li> <li>3. Prilikom prijave reklamacije koristiti date oznake elemenata</li> </ol>
<p><b>MK</b></p> <ol style="list-style-type: none"> <li>1. Монтажа да се врши на чиста и мека подлога (karton, ткаенина)</li> <li>2. За да се избегне оштетување на елементите придржувајте се на дадените инструкции</li> <li>3. За пријава на рекламации користете ги дадените ознаки на елементите</li> </ol>	<p><b>AL</b></p> <ol style="list-style-type: none"> <li>1. Montimi të bëhet në sipërfaqe të pastër dhe të butë (karton, pëlhurë)</li> <li>2. Që t'u shmangeni dëmtimit të elementeve, përmbahuni instrukcioneve të dhëna</li> <li>3. Me rastin e reklamimit përdorni shenjat e dhëna të elementit</li> </ol>
<p><b>PL</b></p> <ol style="list-style-type: none"> <li>1. Montować należy na czystej i miękkiej powierzchni (karton, tkanina)</li> <li>2. Aby uniknąć uszkodzenia elementów należy postępować ściśle według instrukcji.</li> <li>3. Przy zgłaszaniu reklamacji należy posługiwać się załączonymi oznaczeniami elementów.</li> </ol>	<p><b>HR</b></p> <ol style="list-style-type: none"> <li>1. Pažljivo pročitajte upute za montažu</li> <li>2. Pripremite sve dijelove namještaja</li> <li>3. Prikupite i provjerite okove za montažu</li> <li>4. Pripremite potreban alat</li> <li>5. Pripremite prostor za montažu</li> <li>6. Počnite montirati</li> <li>7. Sačuvajte ove ove upute</li> <li>8. Proizvod je namjenjen isključivo za kućnu uporabu</li> </ol>
<p><b>PT</b></p> <ol style="list-style-type: none"> <li>1. A montagem deve ser feita em uma superfície limpa e macia (papelão, tecido...)</li> <li>2. Para evitar danos nos elementos, siga as instruções fornecidas.</li> <li>3. Durante a apresentação de reclamação usar os rótulos dos elementos fornecidos.</li> </ol>	
<p><b>NL BE</b></p> <ol style="list-style-type: none"> <li>1. De installatie moet worden uitgevoerd op een schoon en zacht oppervlak (karton, stof...)</li> <li>2. Volg de gegeven instructies om schade aan de elementen te voorkomen.</li> <li>3. Gebruik bij het melden van een klacht de gegeven elementlabels.</li> </ol>	

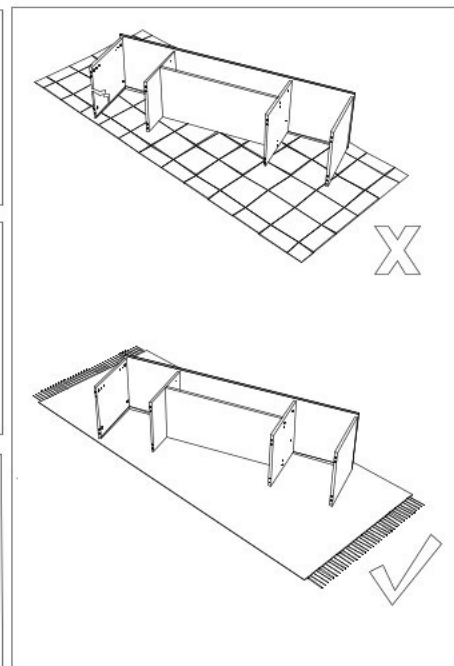
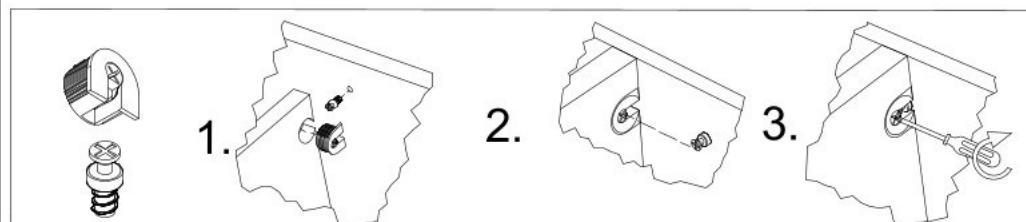
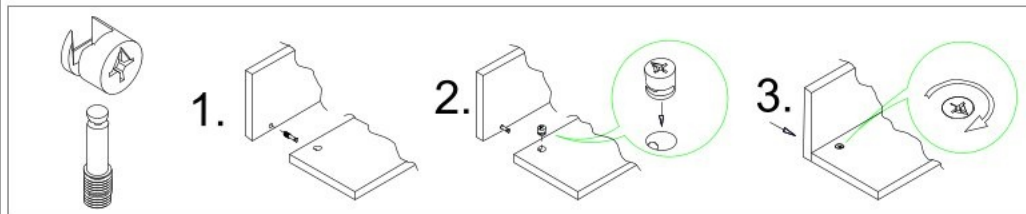
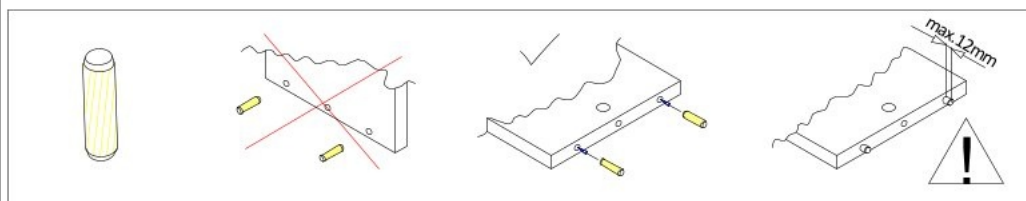

A	Ø8x30	B		C	Ø7x50	D	1.6 x 25	E		F		G	4x30	H	4x16	I		J	6x60
x51		x18		x43		x106		x2		x2		x8		x72		x4		x4	
K	M4x25	L		M	4x16	N		O		P	M 4x15	Q		R		S		T	
x20		x10		x8		x10		x10		x2		x24		x32		x4		x5	
U	3x25	V		W	4x30	X		Y		Z	Ø8x50	Aa		Ab		Ac	Ø6.3x13	Ad	
x11		x18		x2		x6		x4		x1		x4		x2		x8		x9	
Ae		Af		Ag		Ah	3.5x16	Ai		Aj		Ak		Al		Am		An	
x6		x10		x4		x12		x4		x2		x4		x2		x2		x1	
Ao	L=680mm	Ap		Ar		As		At											
x3		x8		x2		x3		x4											

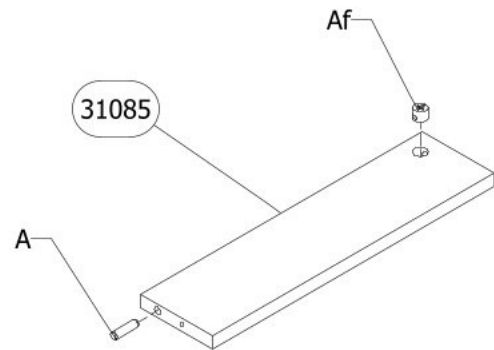
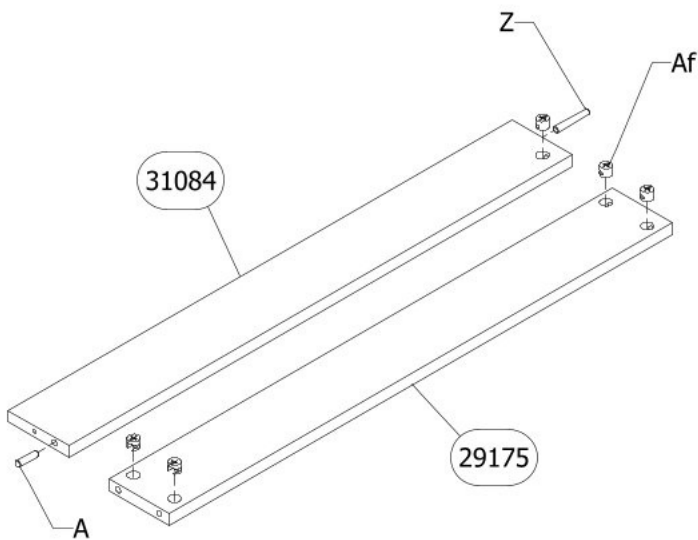
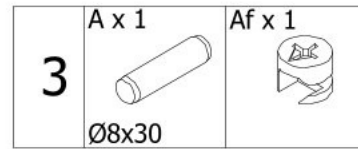
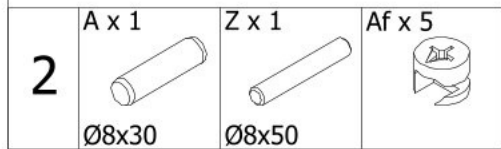
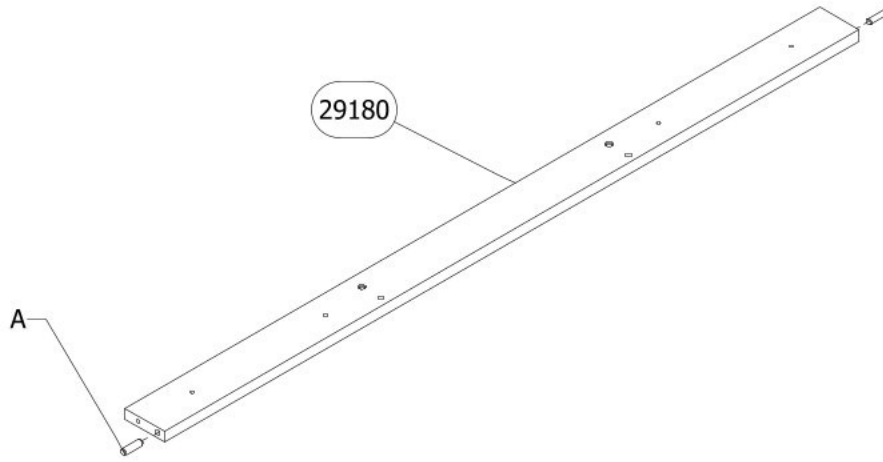
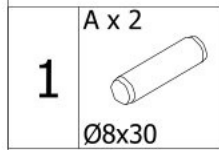

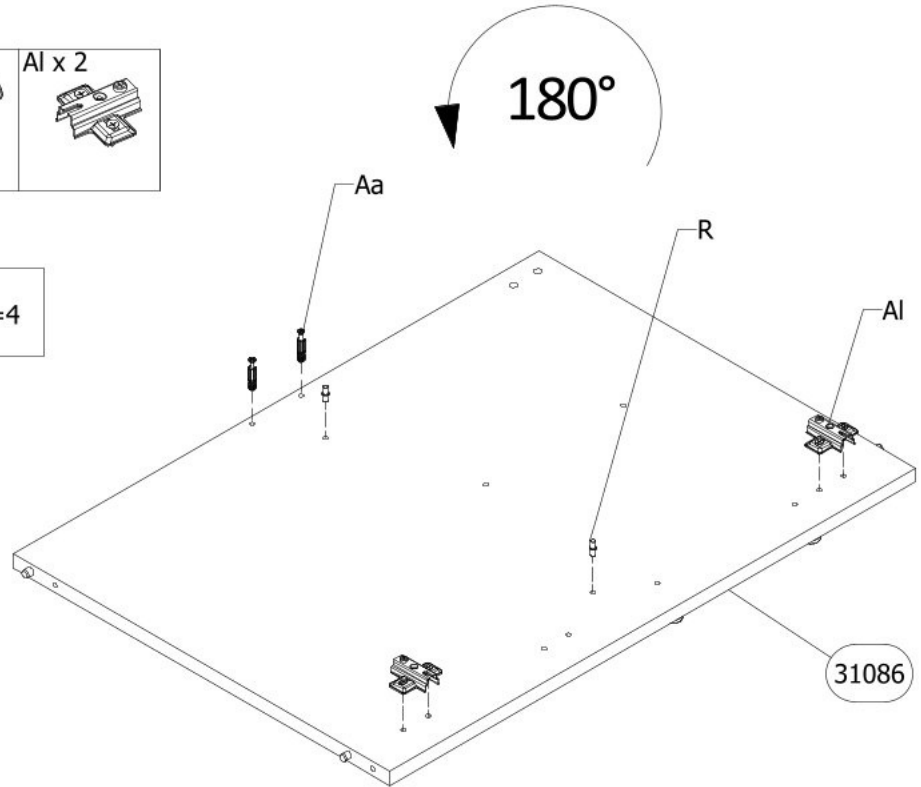
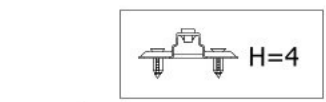
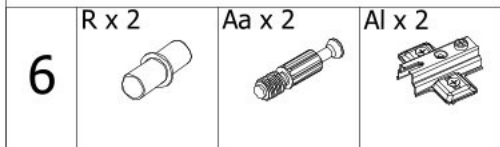
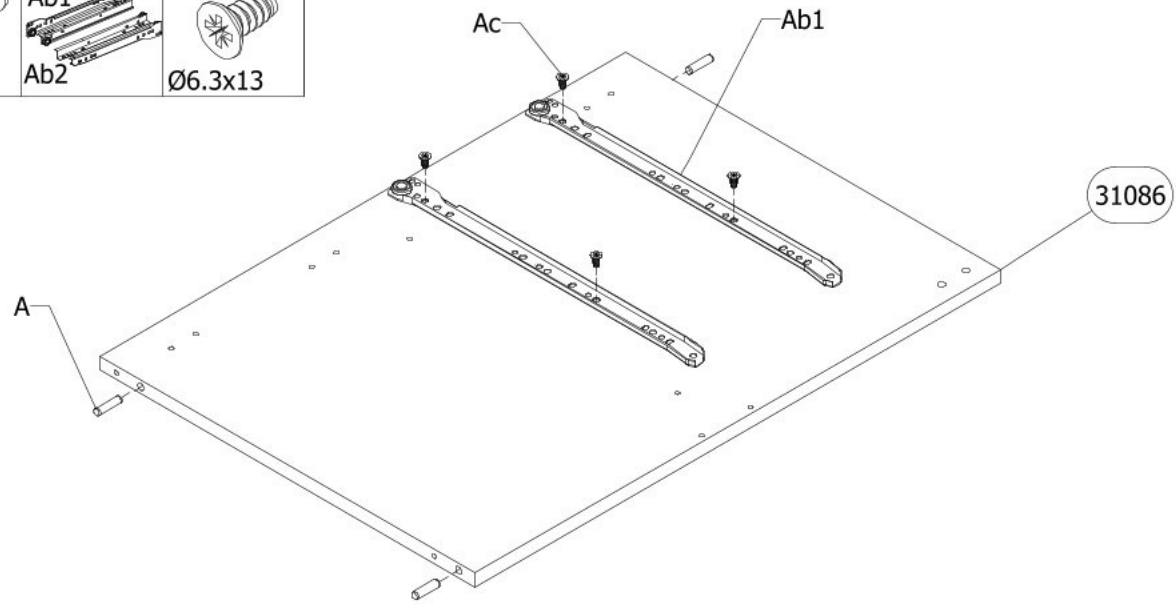
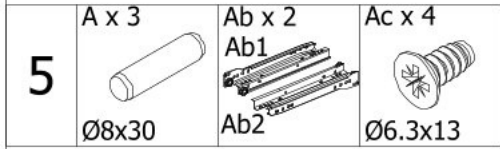
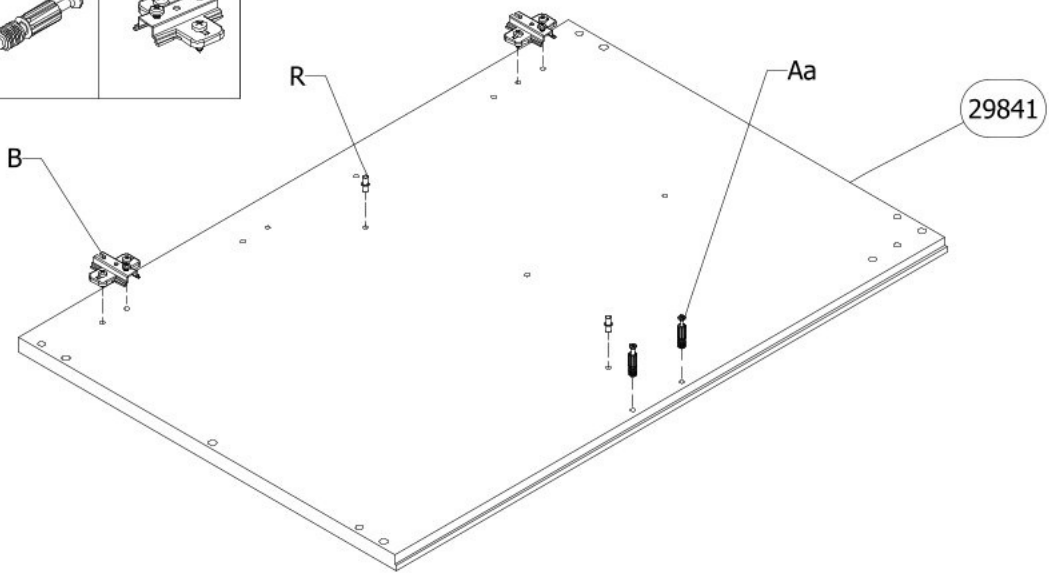
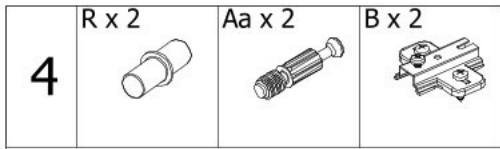

7

Ab x 2

Ab1

Ab2

Ab2

Ac x 4



Ø6.3x13

B x 2

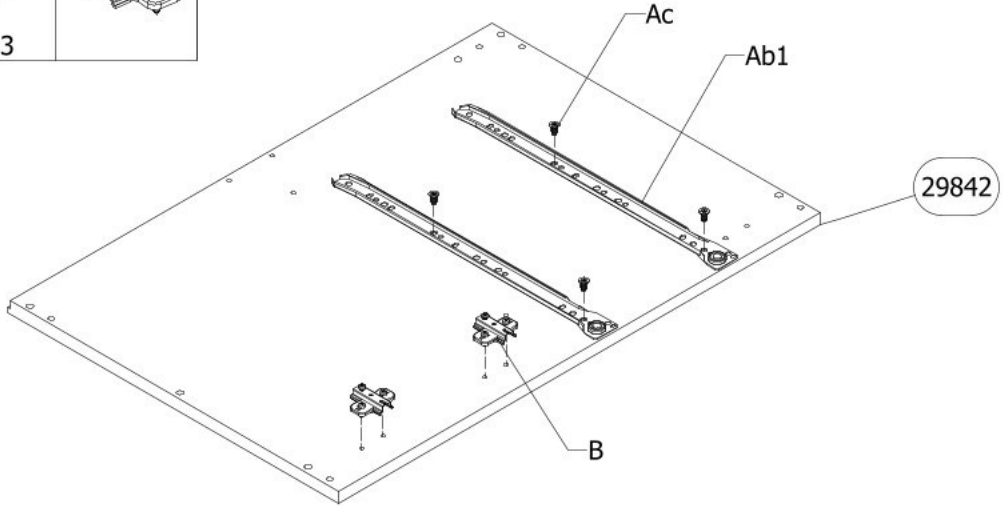
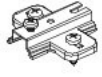

8

A x 6



Ø8x30

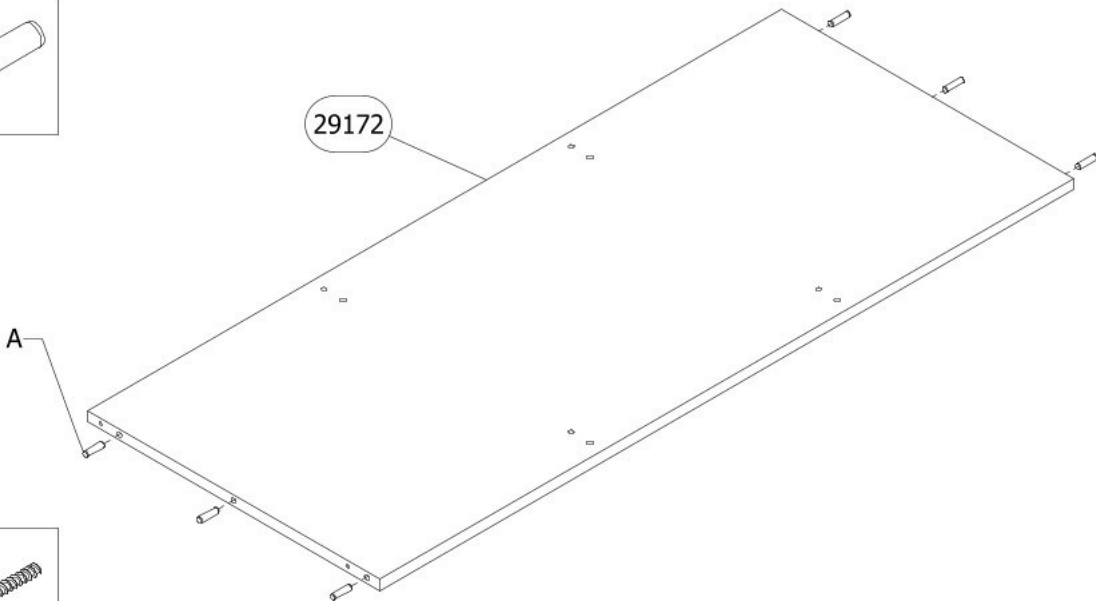

9

C x 2



Ø7x50

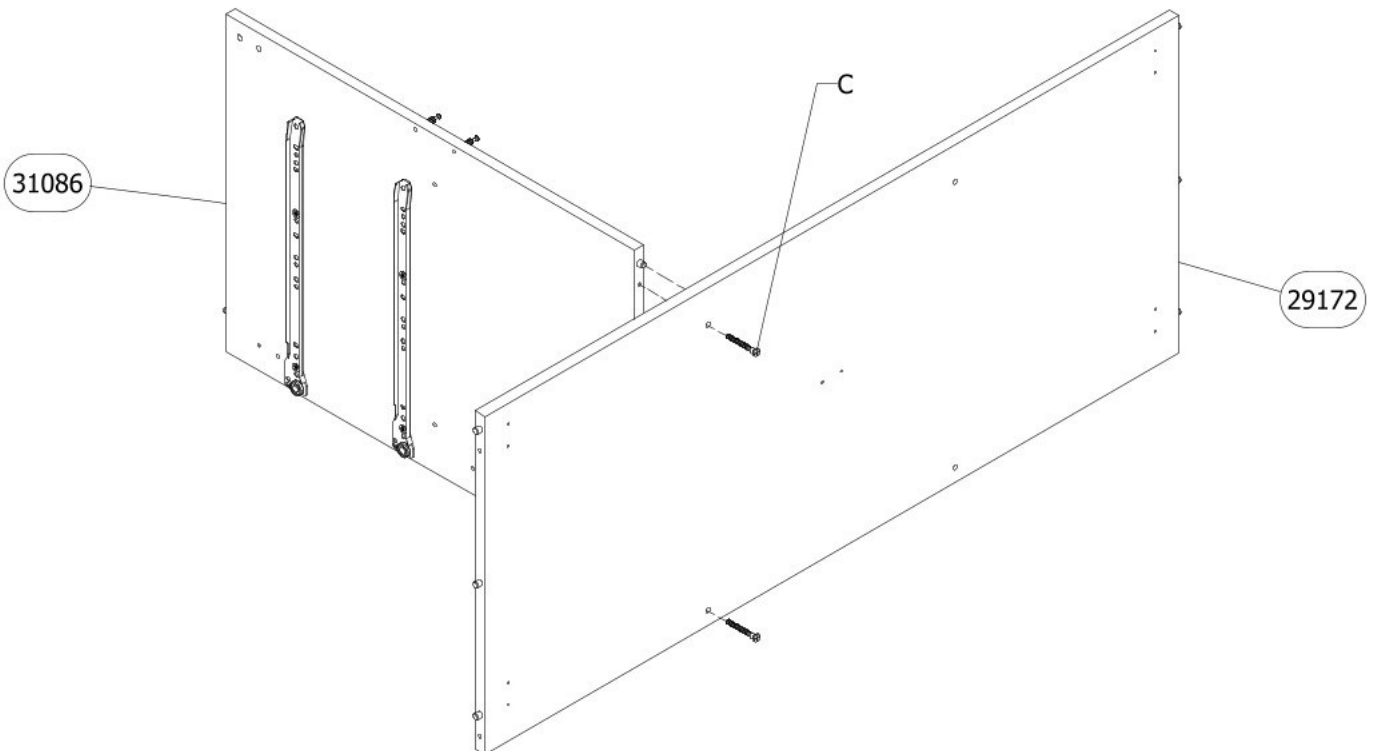

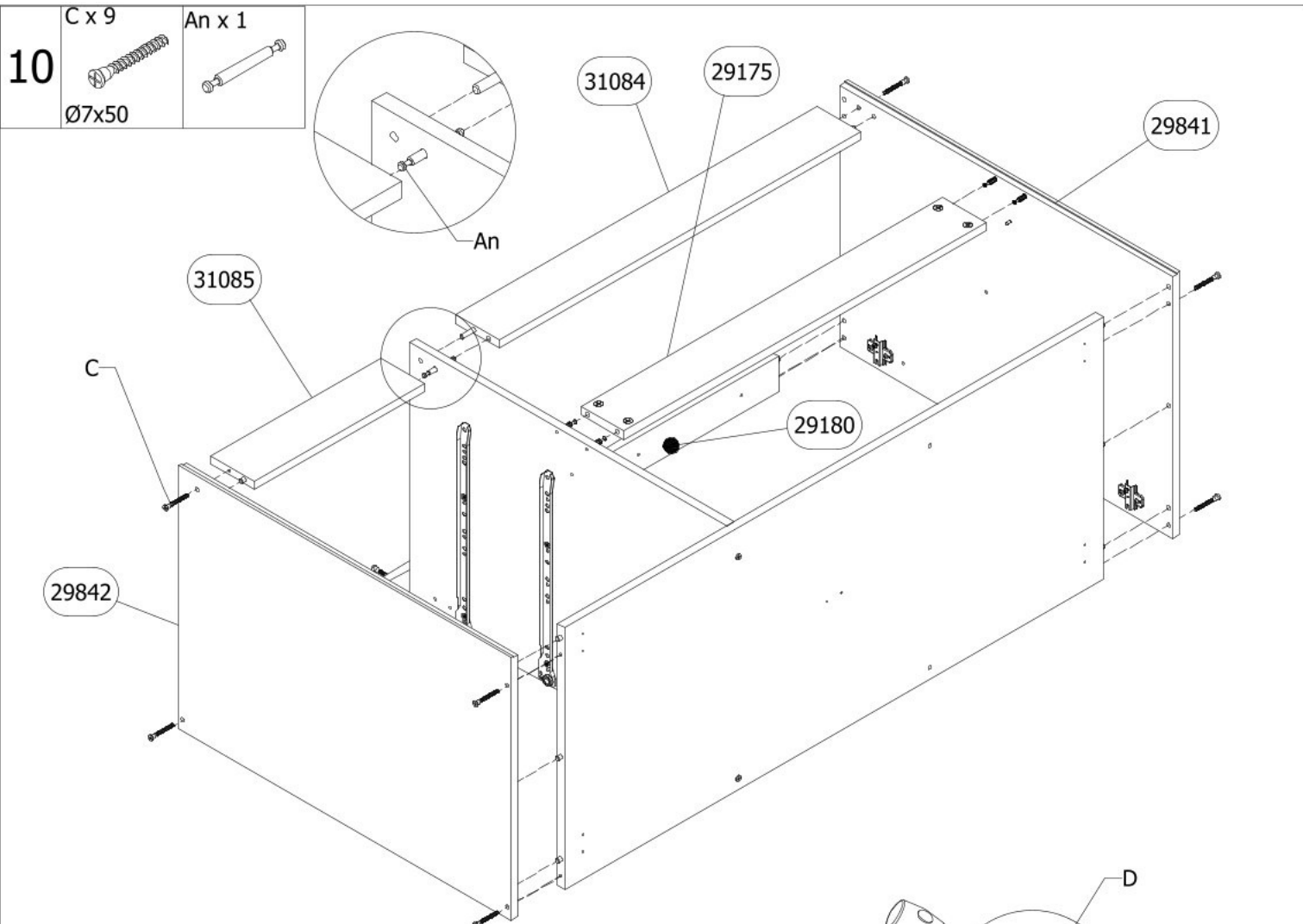

- 10** C x 9  
Ø7x50
- An x 1



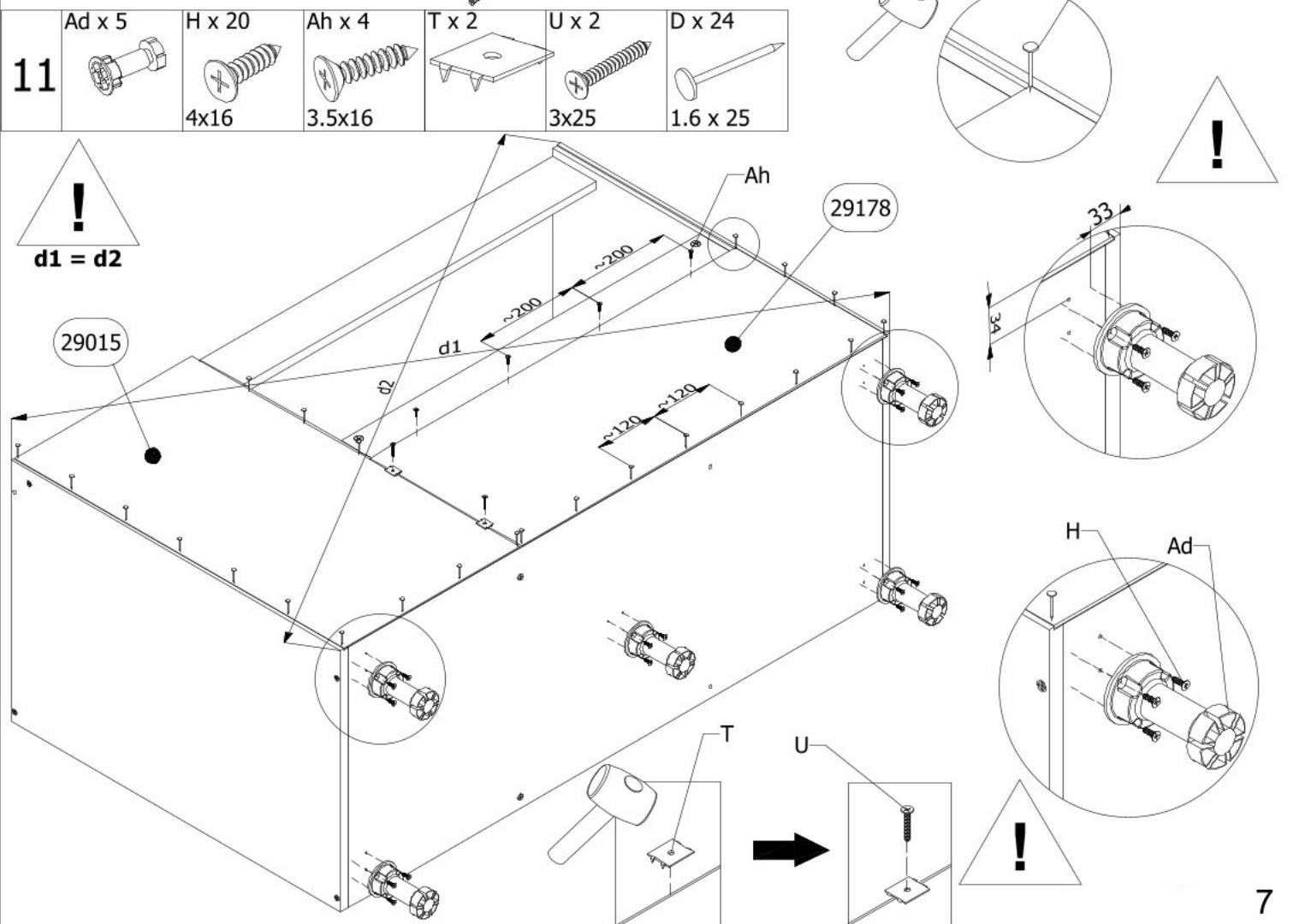



- 11** Ad x 5
- H x 20  
4x16
- Ah x 4  
3.5x16
- T x 2
- U x 2  
3x25
- D x 24  
1.6 x 25

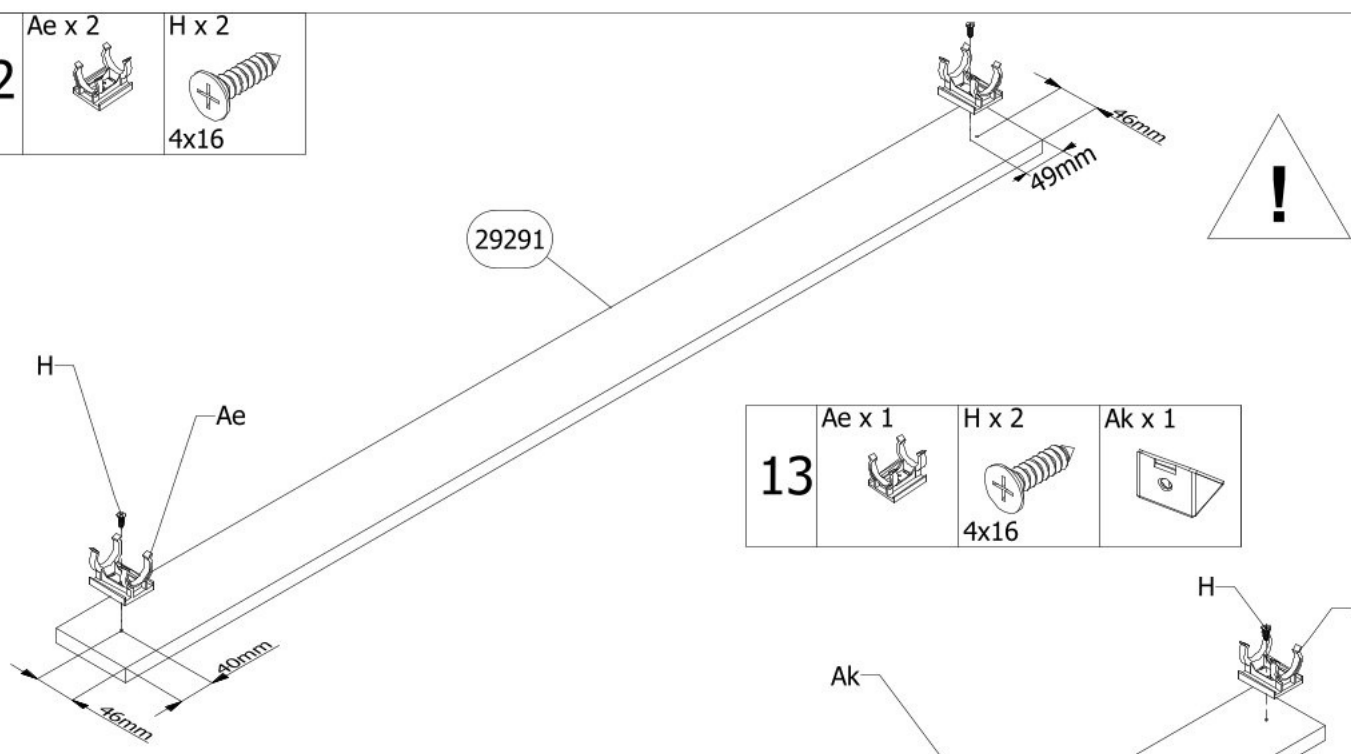

12



Ae x 2	H x 2
	
	4x16

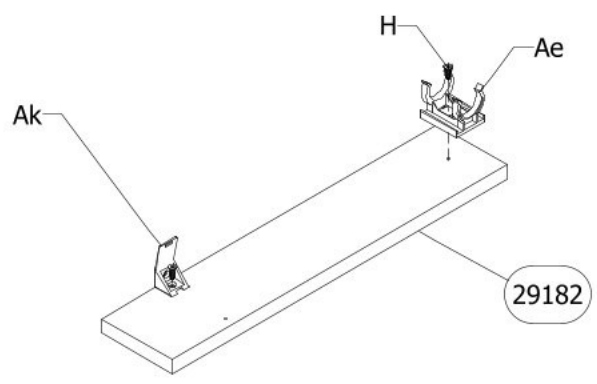

Ae x 1	H x 2	Ak x 1
		
	4x16	

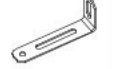

14

H x 6	E x 2	F x 2	Ak x 2
			
4x16			

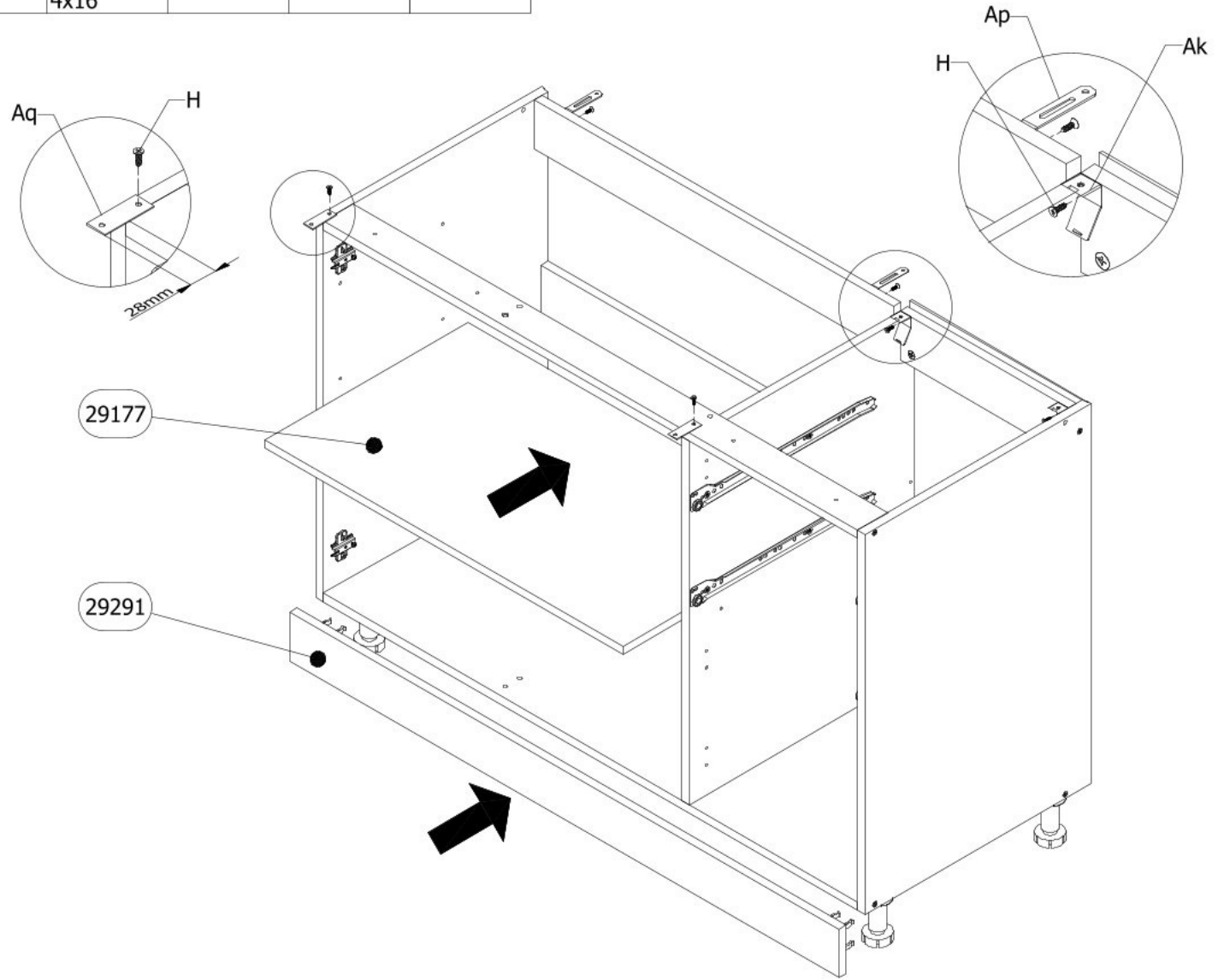



15

H x 5



4x16

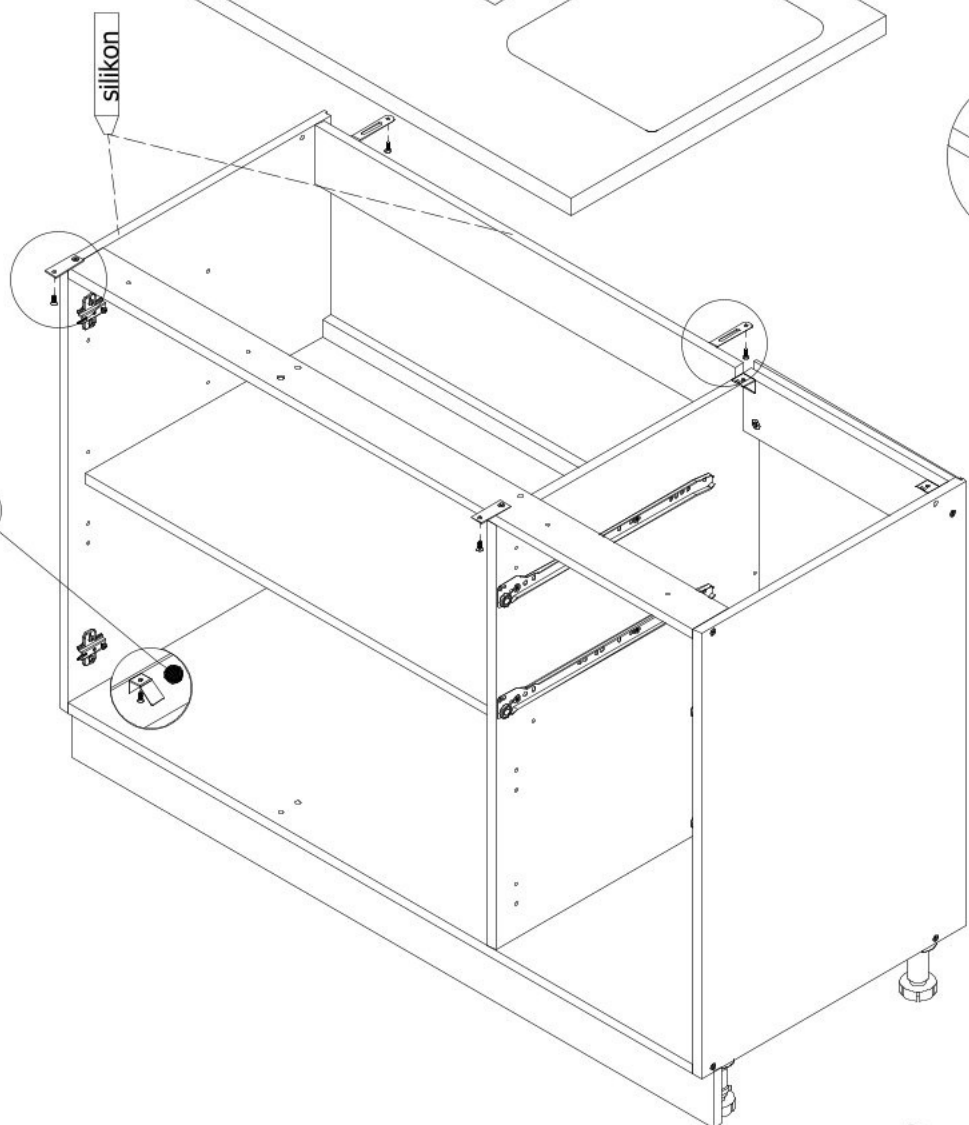
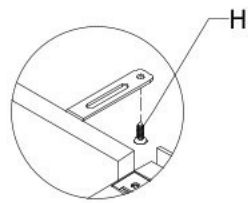
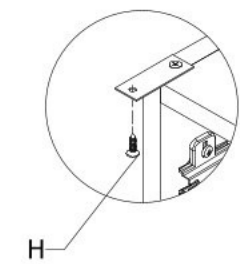

16

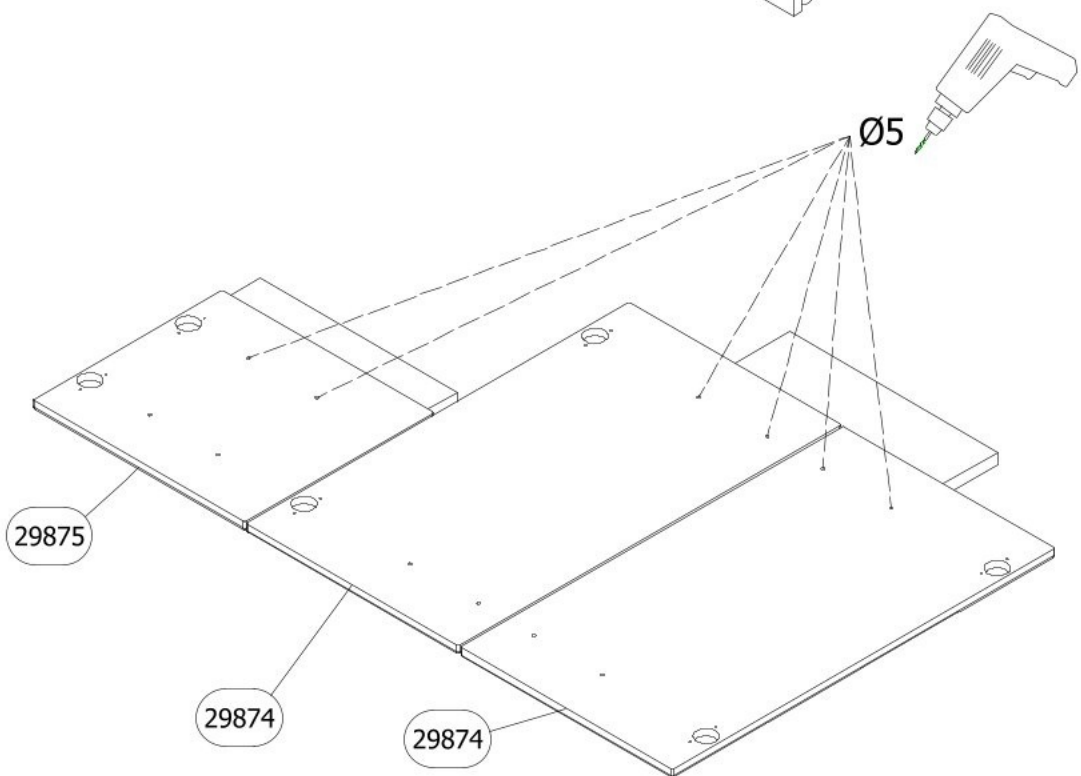

17

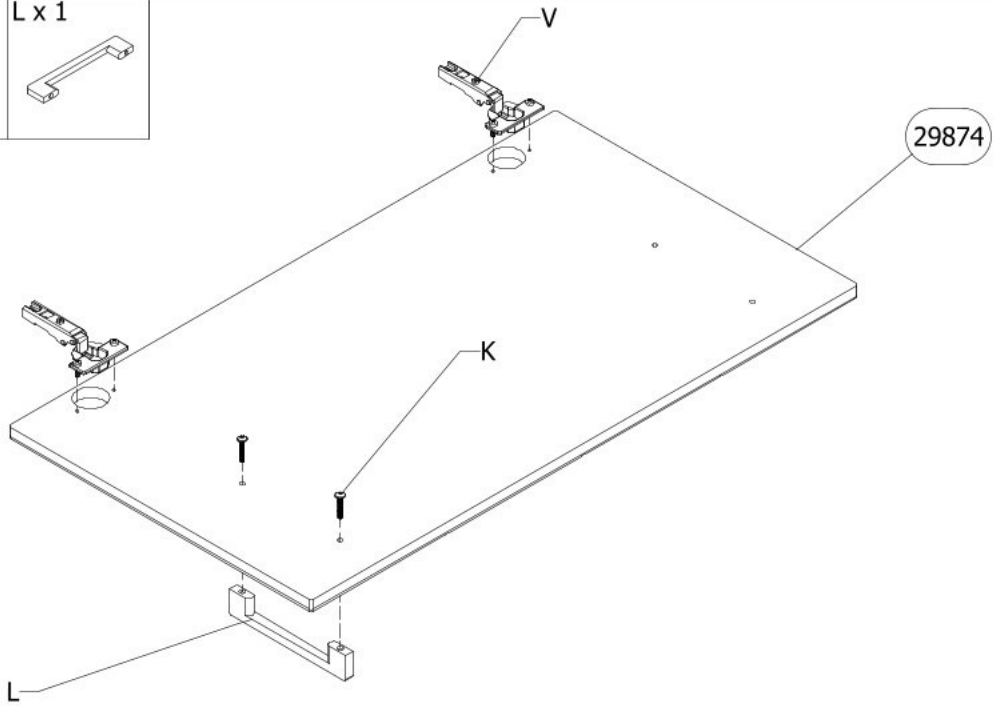
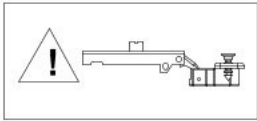

18

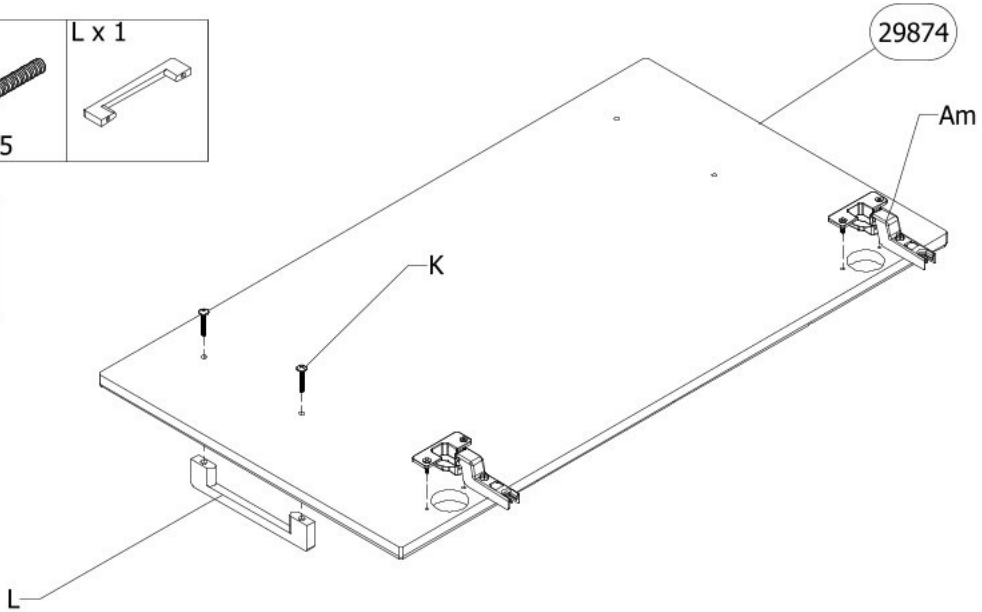
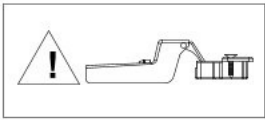

19

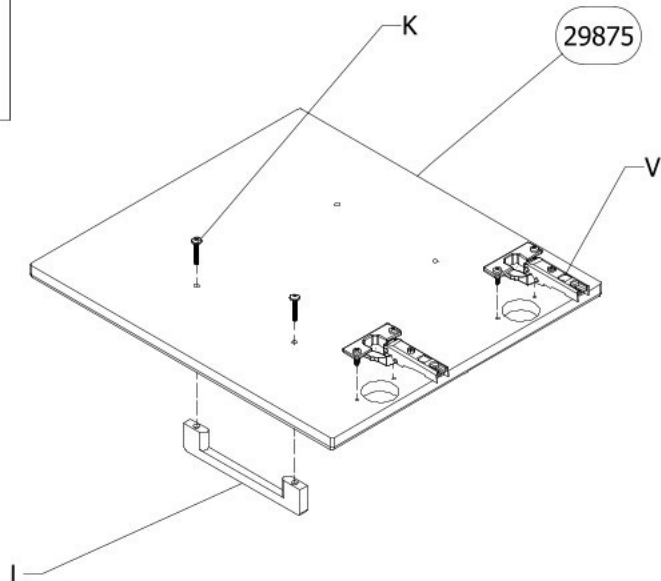
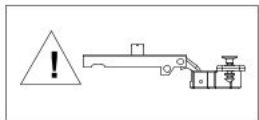
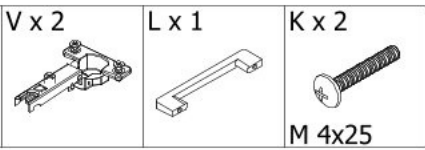

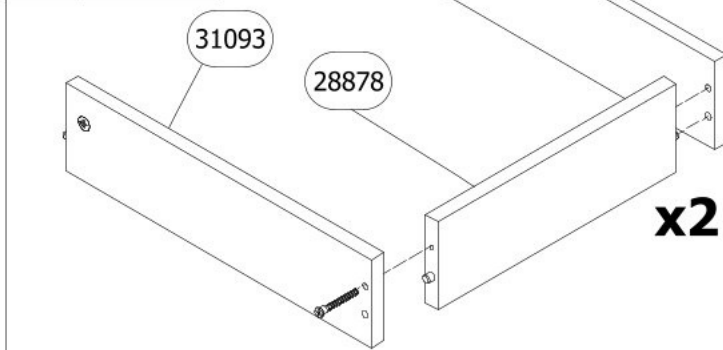
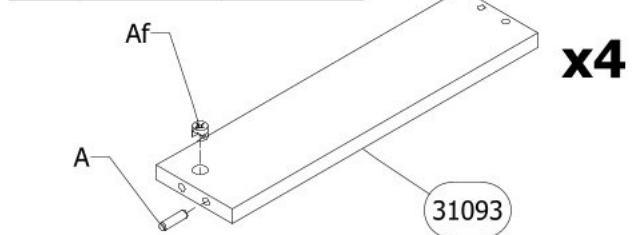
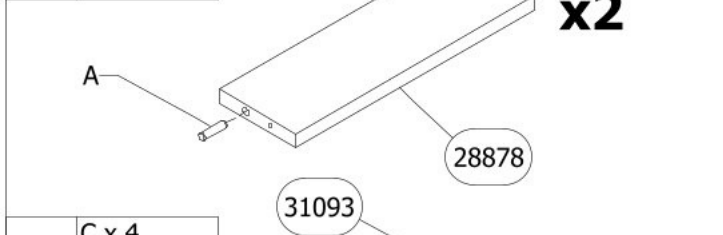
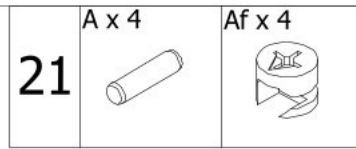
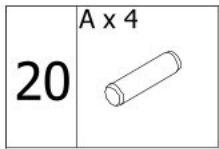

**23**

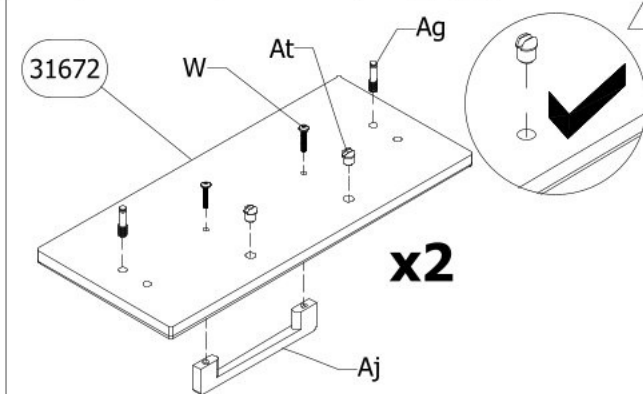
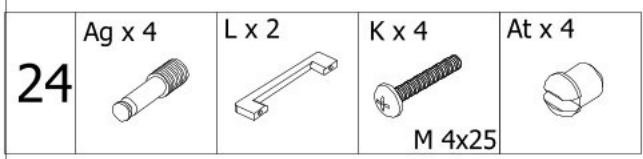
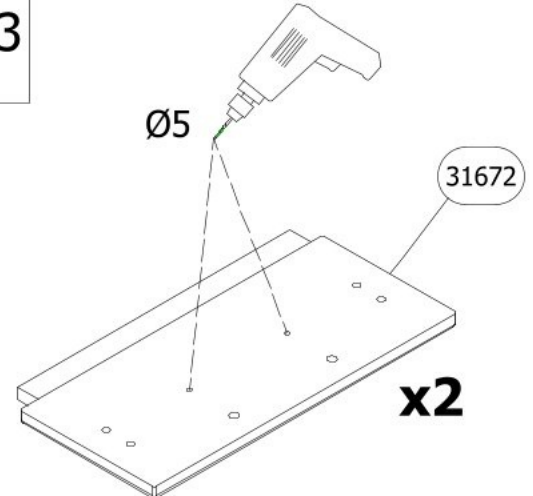

**25**

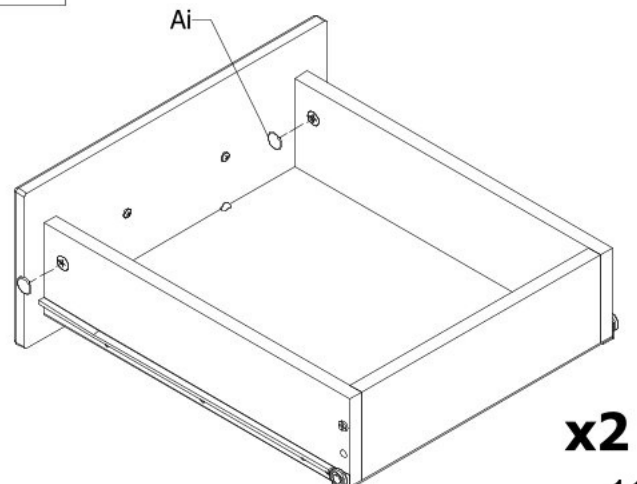
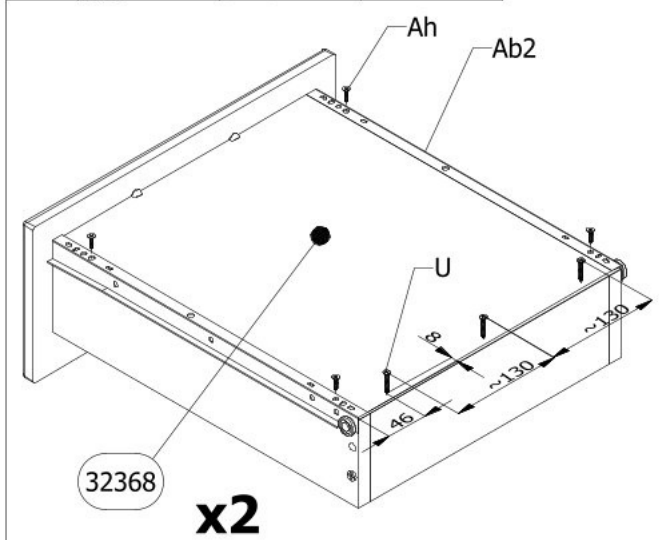
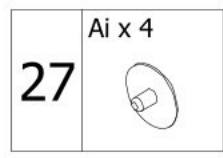
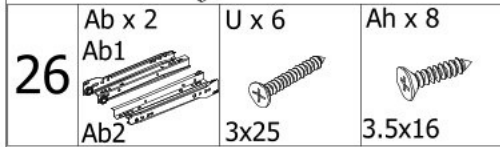
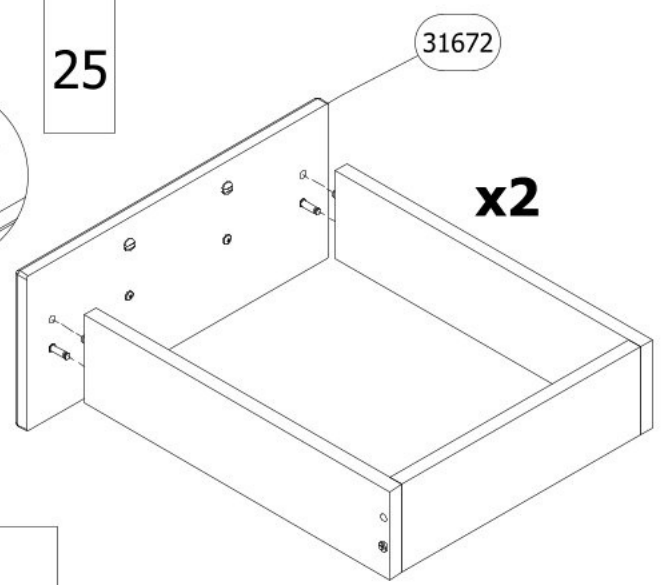

28

N x 4



X x 3



Y x 2



Q x 10

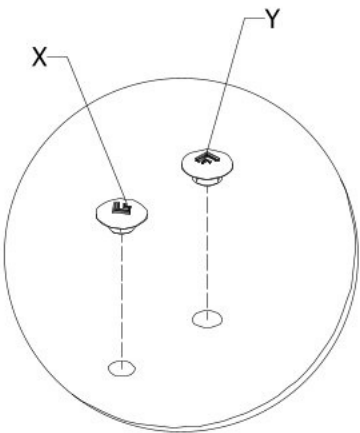
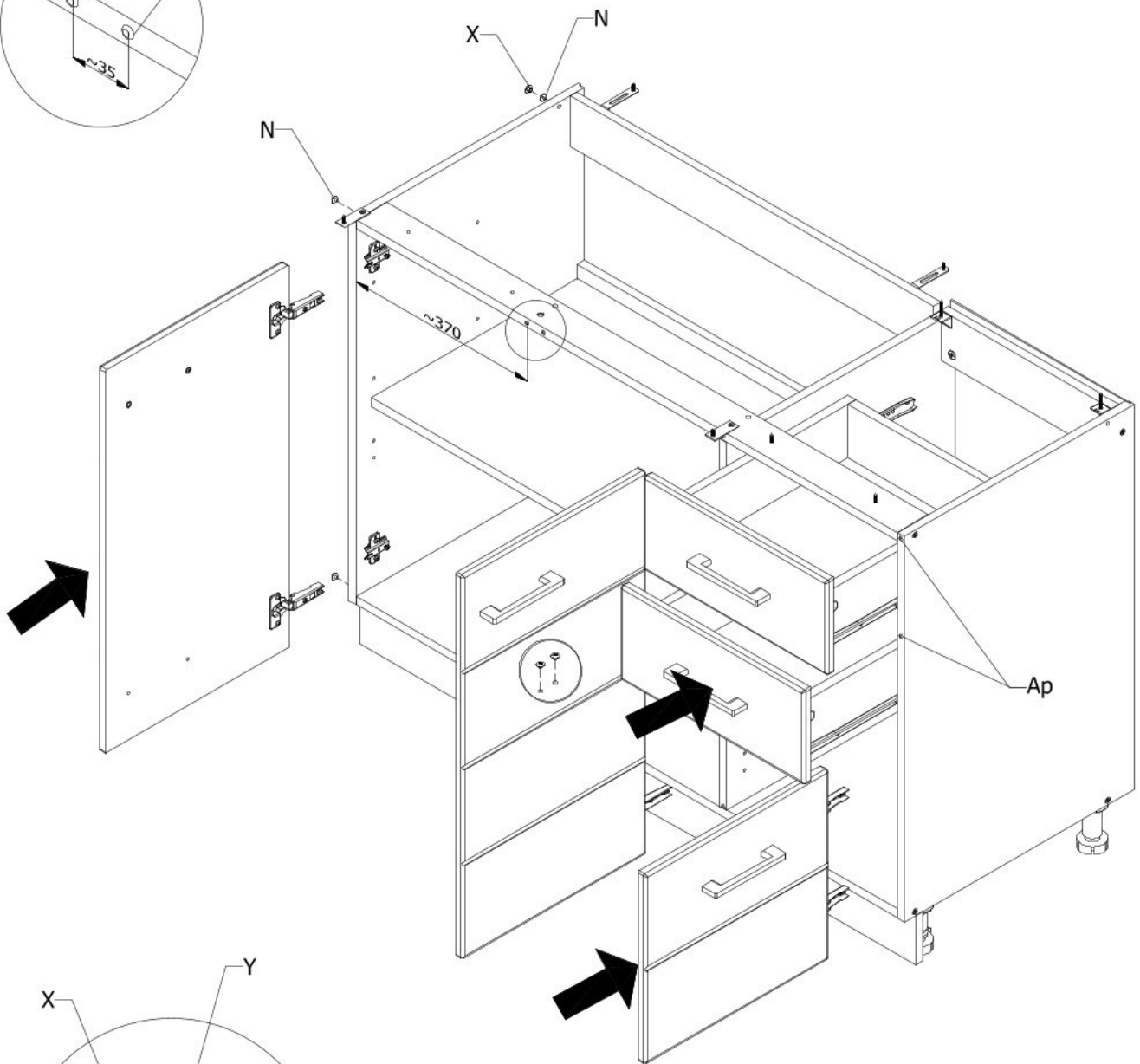
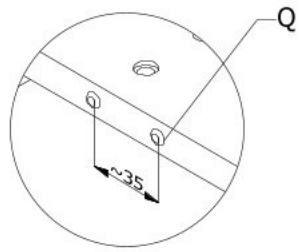

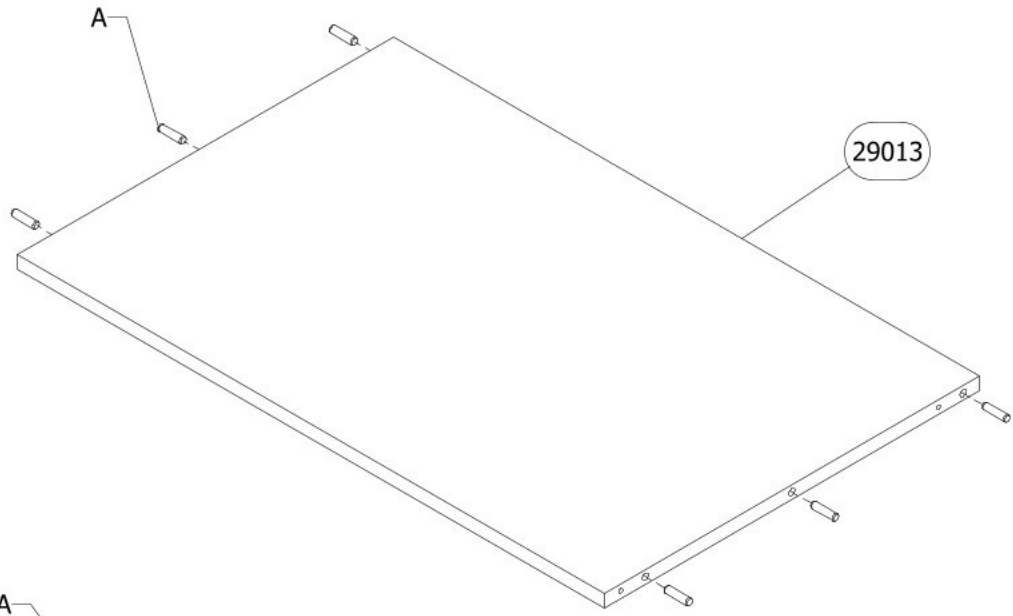

**29** A x 6  
  
 Ø8x30

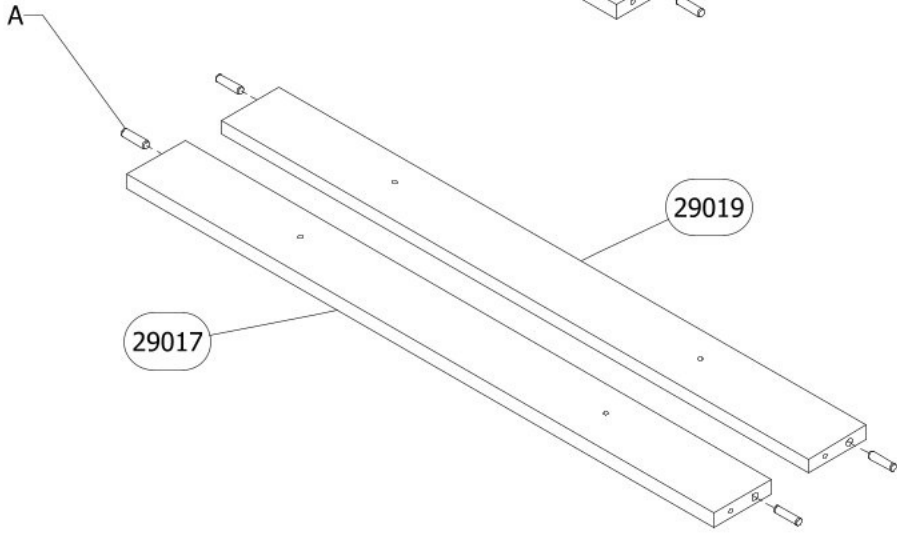

**30** A x 4  
  
 Ø8x30

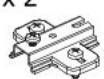

**31** B x 2 R x 2  
  

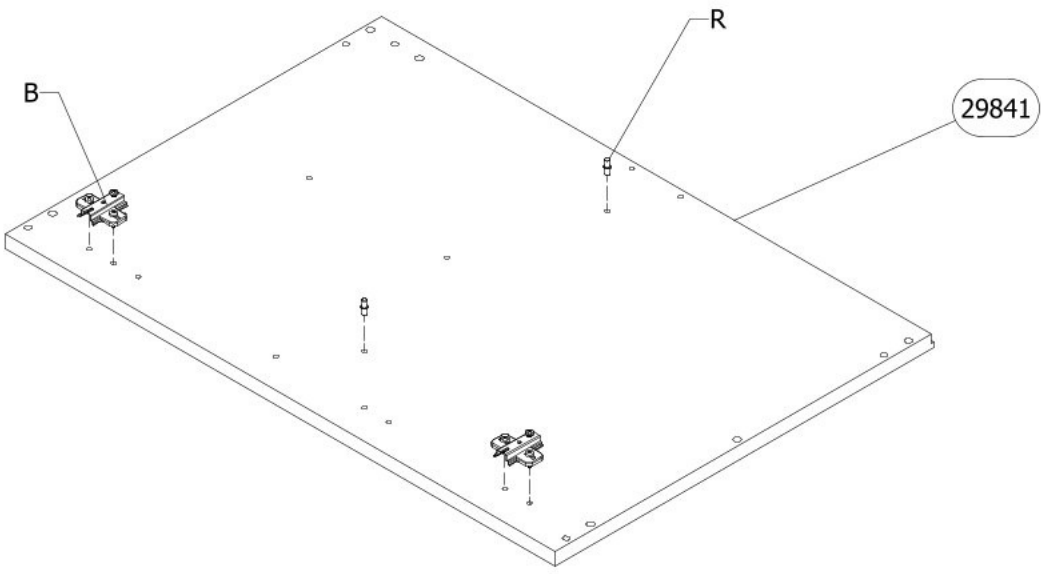

32

B x 2



R x 2

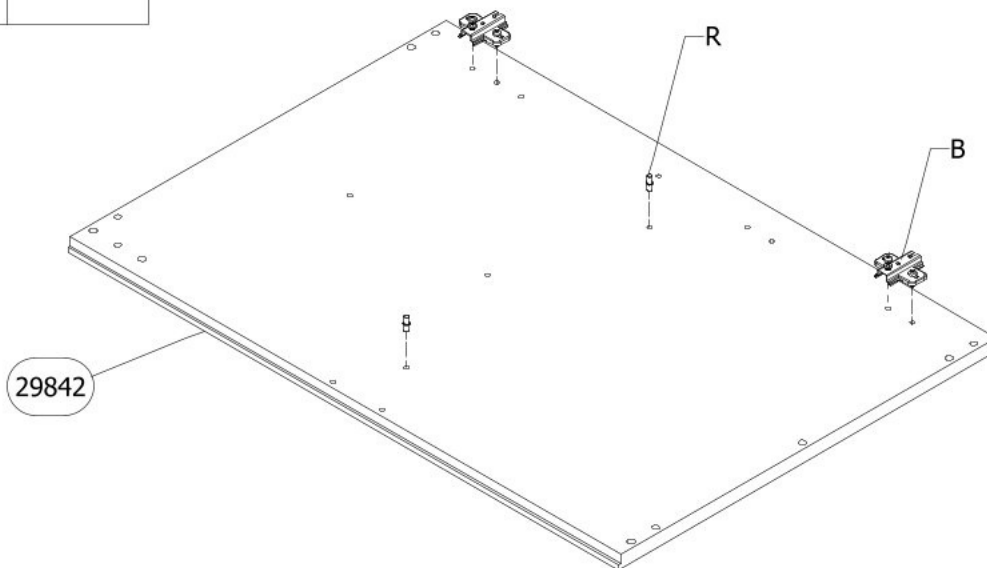

29842

33

C x 8



Ø7x50

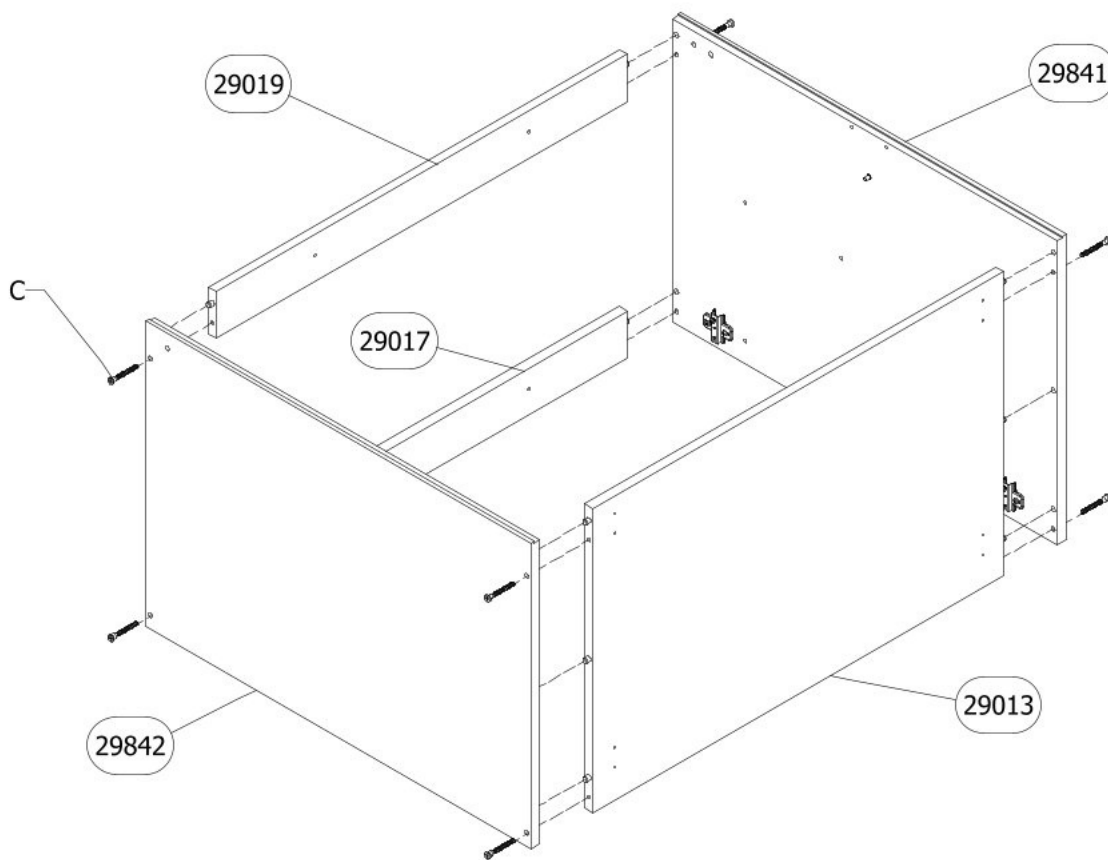

29019

29841

29017

29842

29013

<b>34</b>	D x 24 1.6 x 25	Ad x 4	H x 16 4x16	Ao x 1 L=680mm
-----------	--------------------	--------	----------------	-------------------

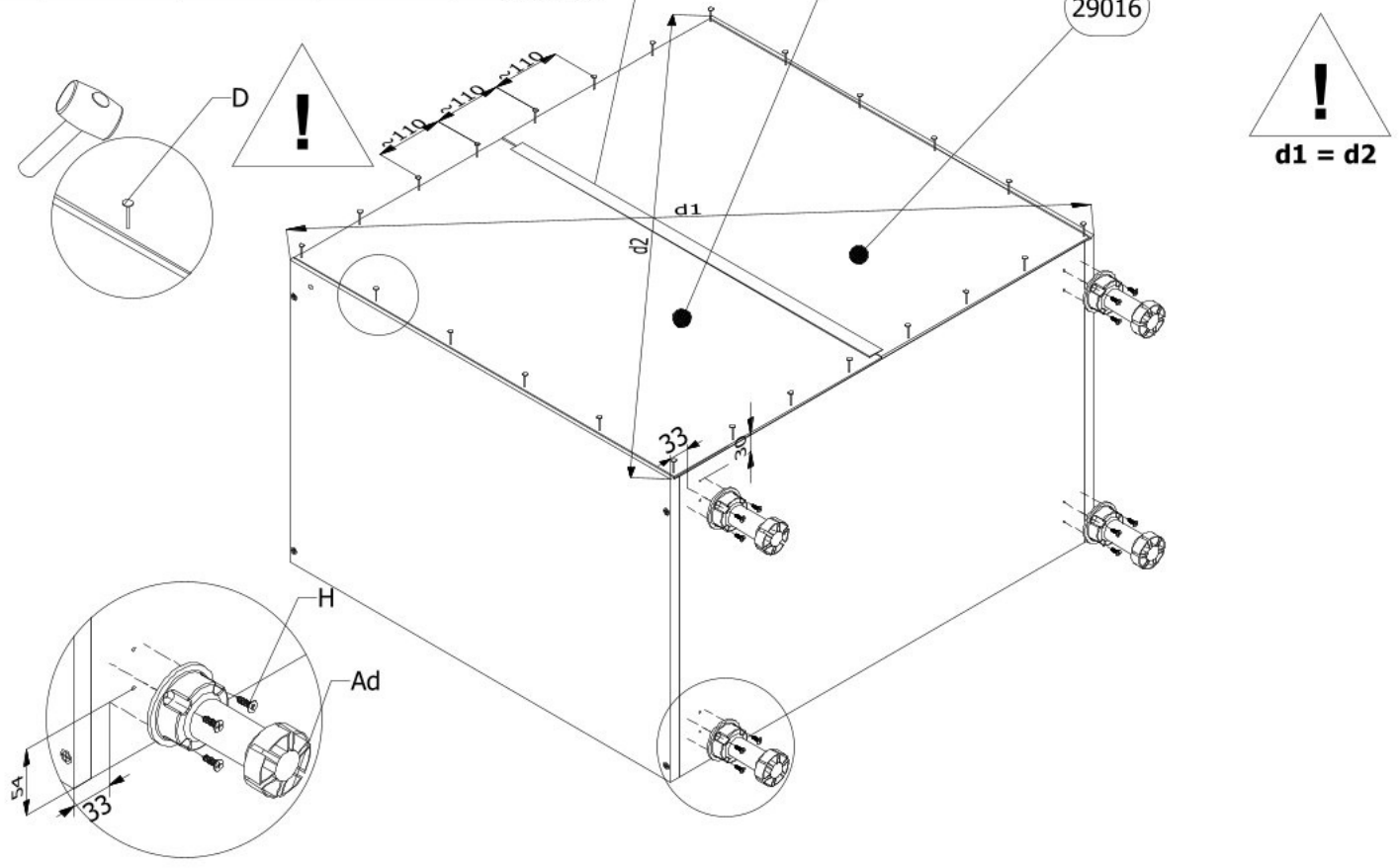

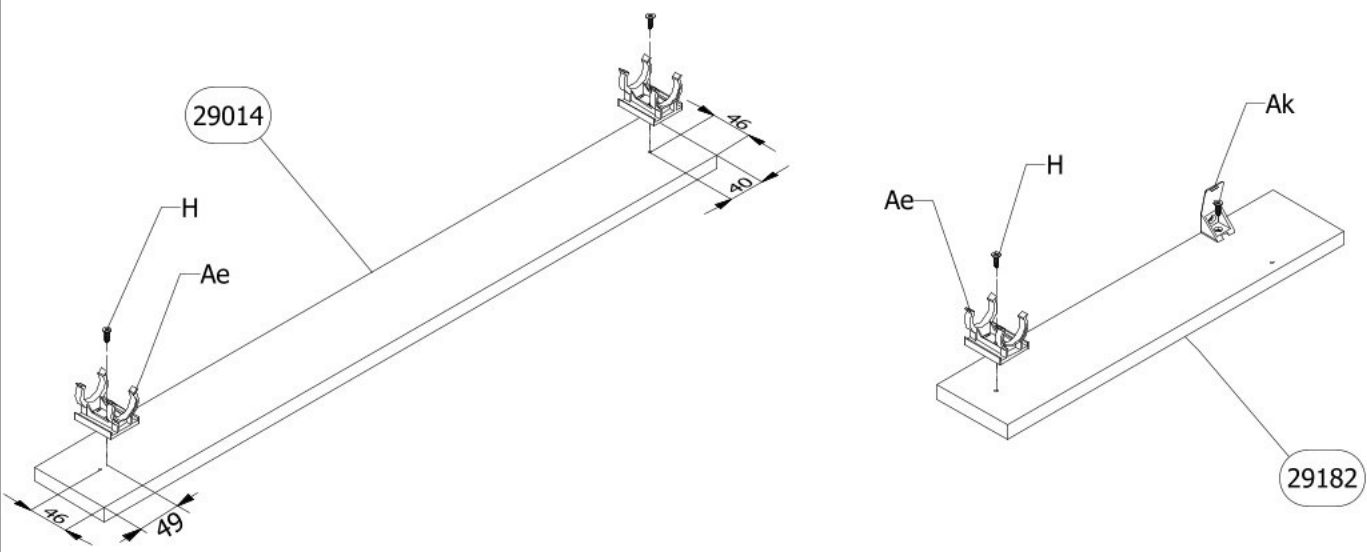

<b>35</b>	Ae x 2	H x 2 4x16
-----------	--------	---------------

<b>36</b>	H x 2 4x16	Ae x 1	Ak x 1
-----------	---------------	--------	--------

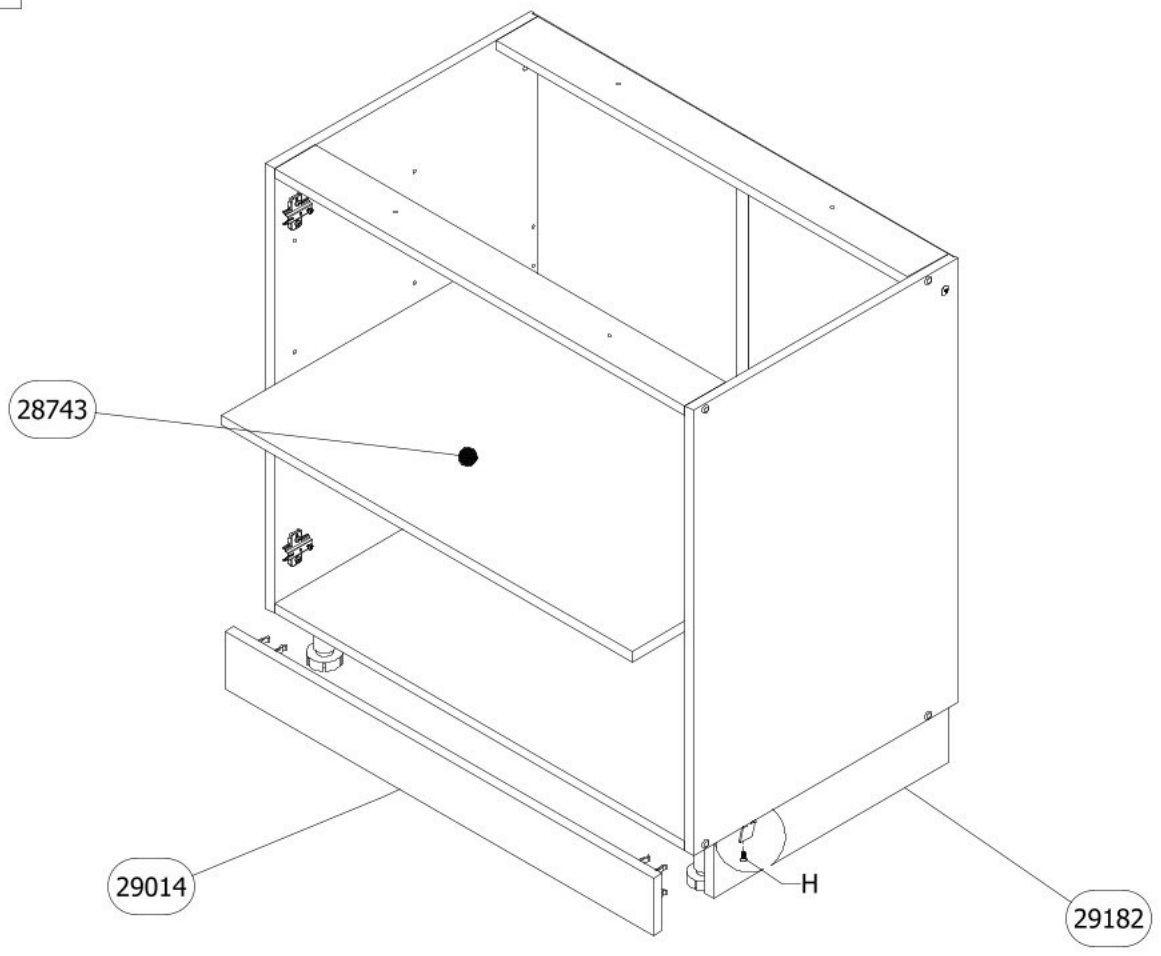

37 H x 1  
4x16



38

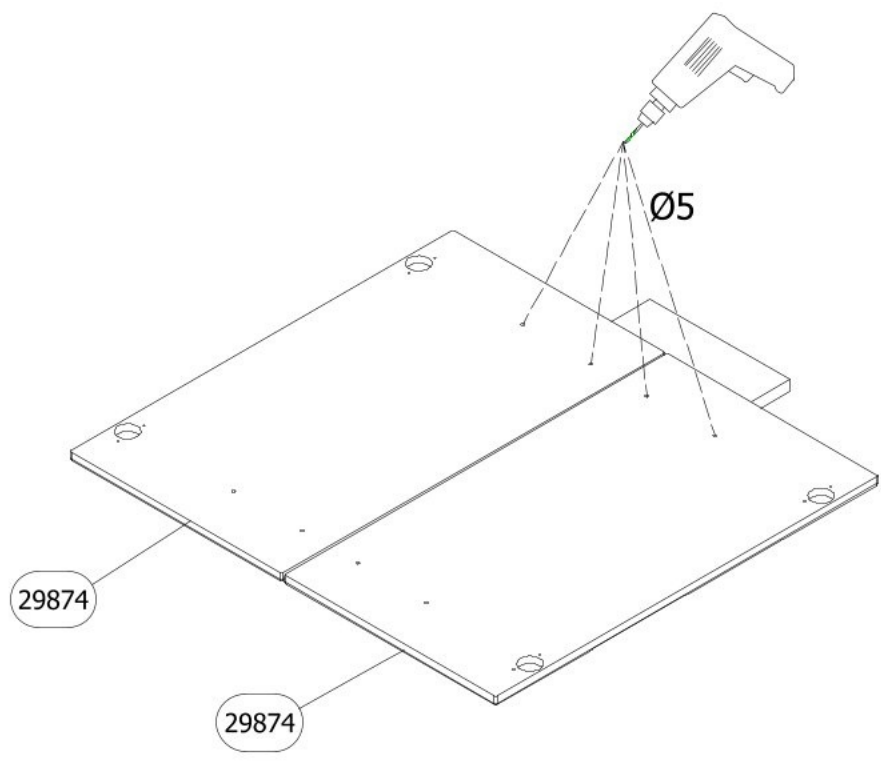



- 39** L x 1 K x 2 V x 2  
M 4x25

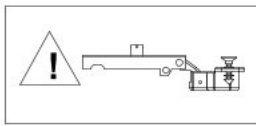

29874

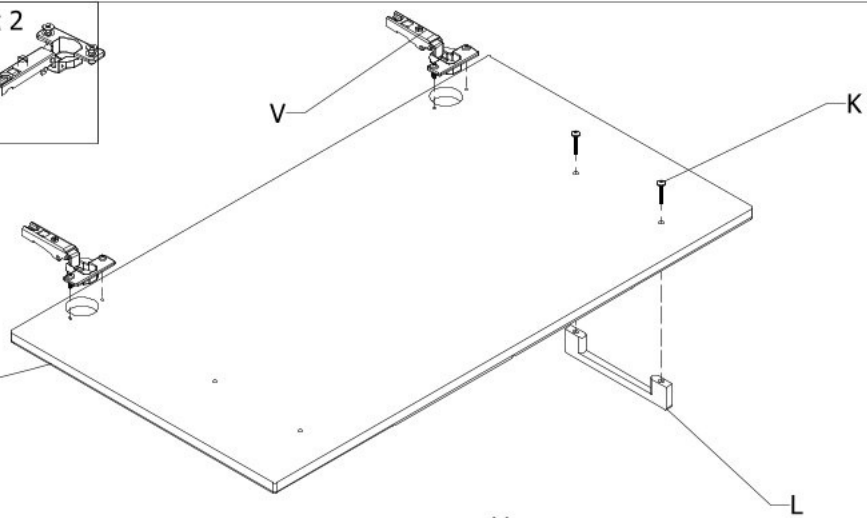

- 40** L x 1 K x 2 V x 2  
M 4x25

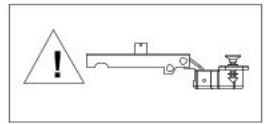

29874

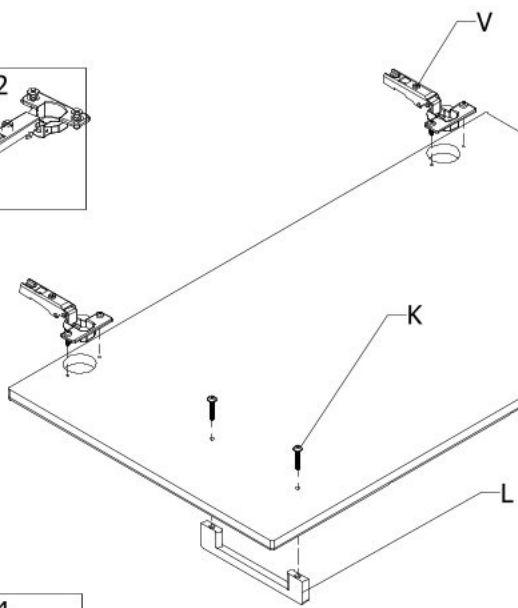

- 41** N x 4 X x 1 Q x 4

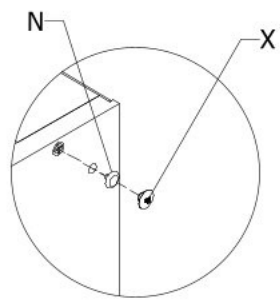
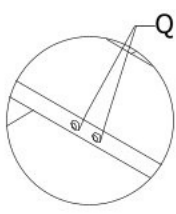

29874

29874

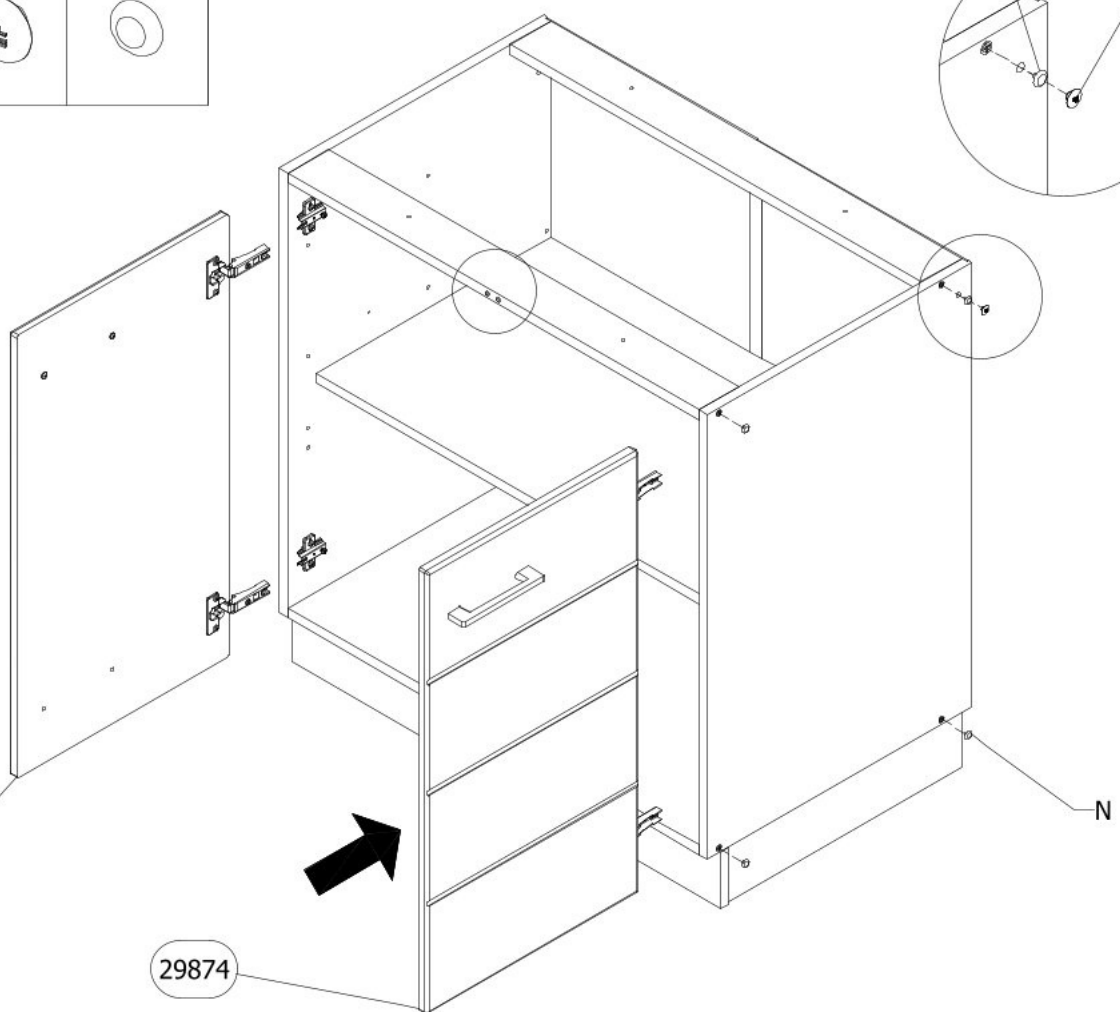

42

W x 2



4x30

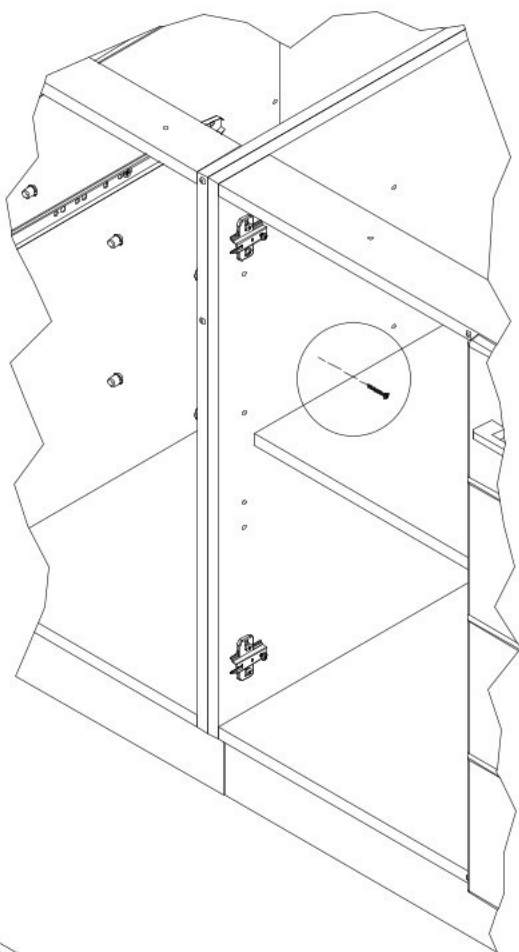
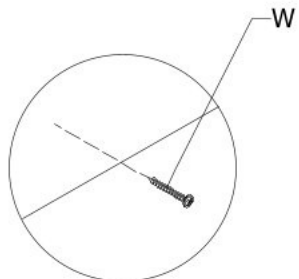

43

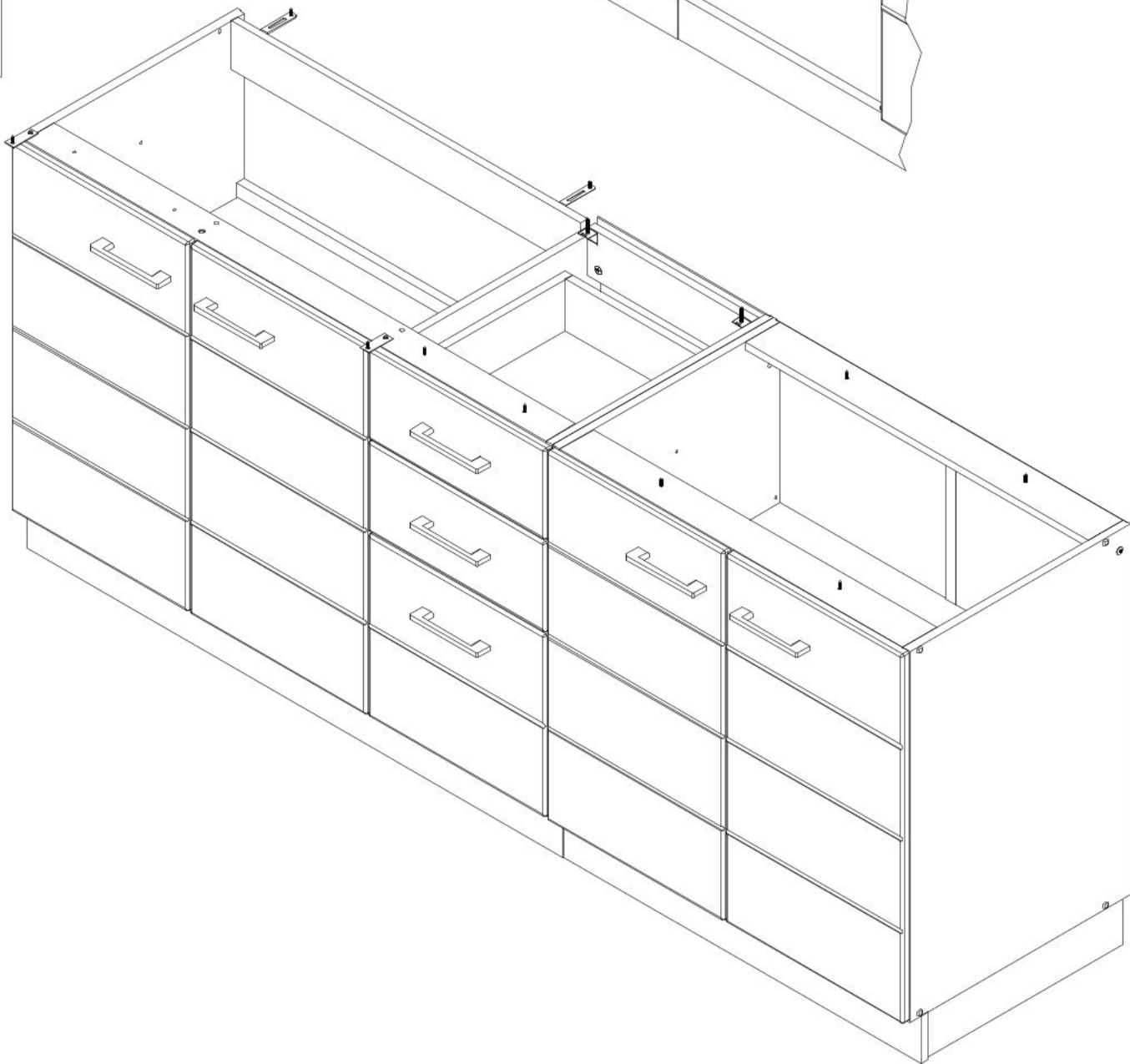

44 A x 8  
Ø8x30

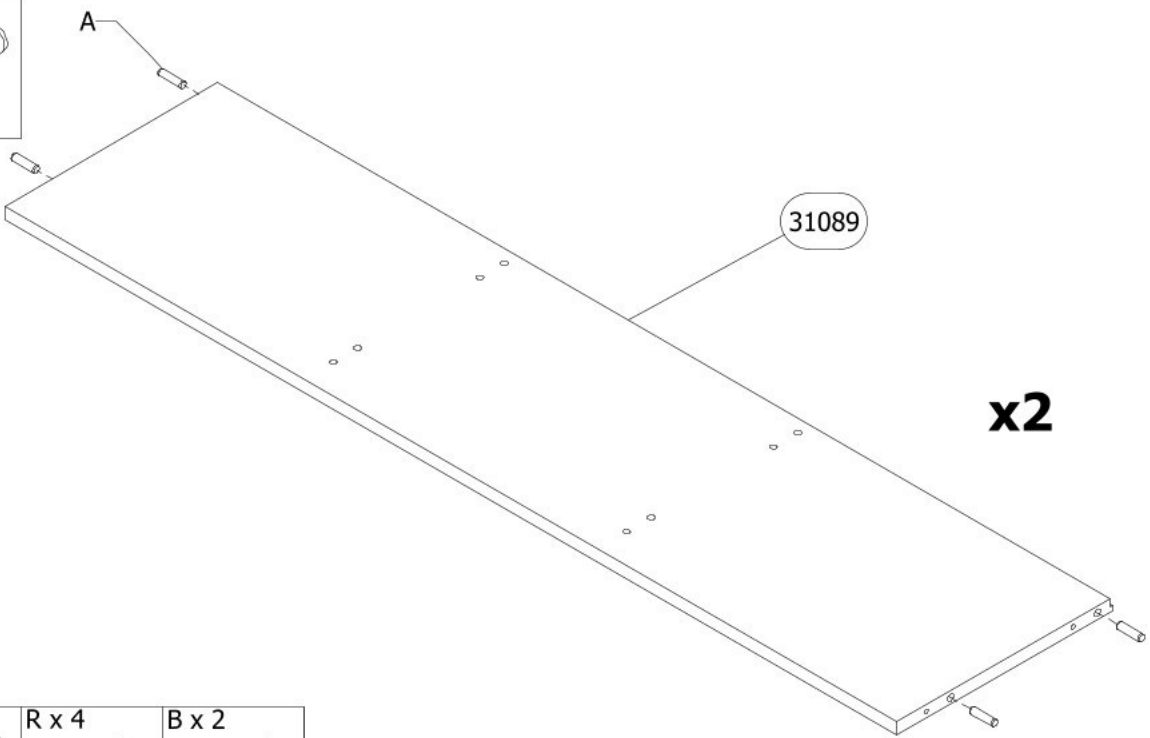

45 A x 4 R x 4 B x 2  
Ø8x30

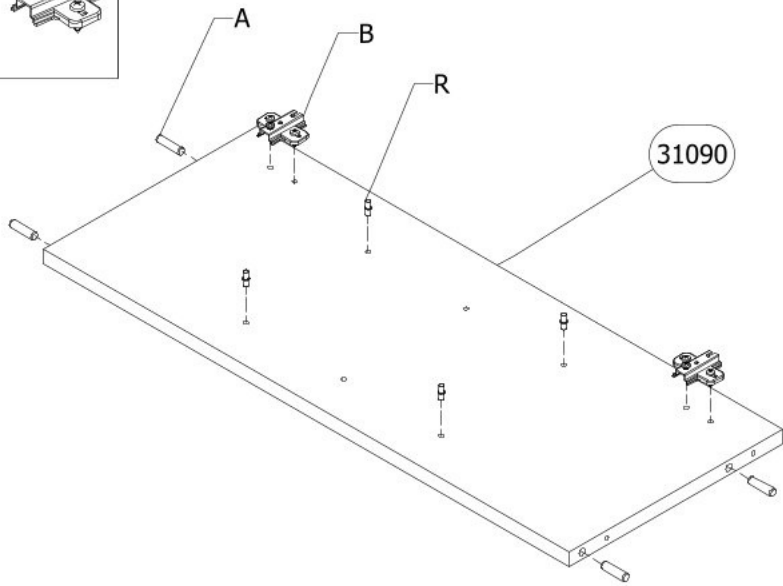

46 R x 8 B x 4

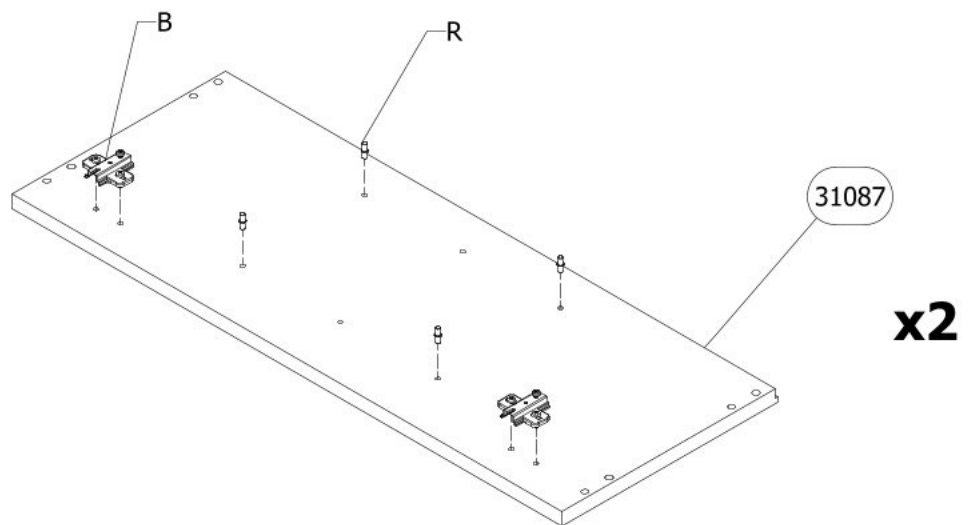

47

C x 4

R x 4

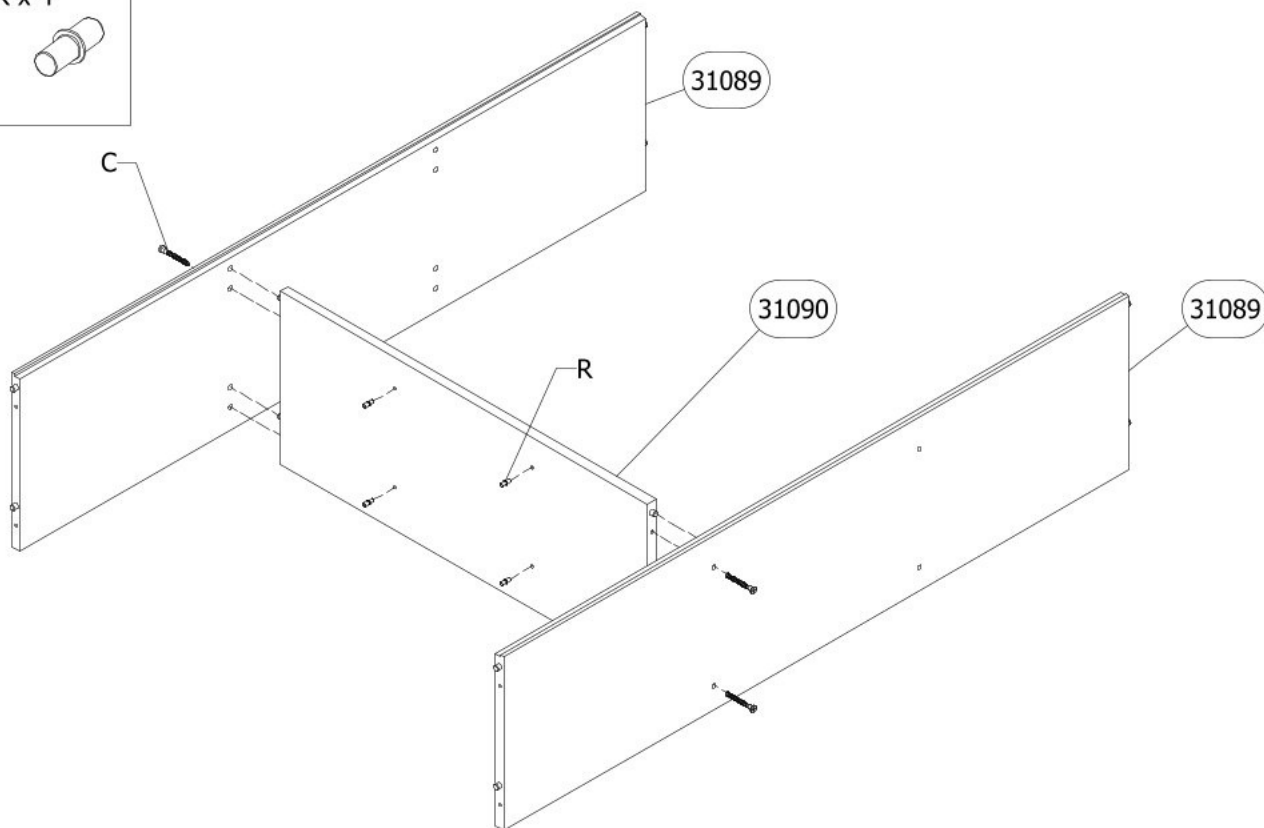

48

C x 8

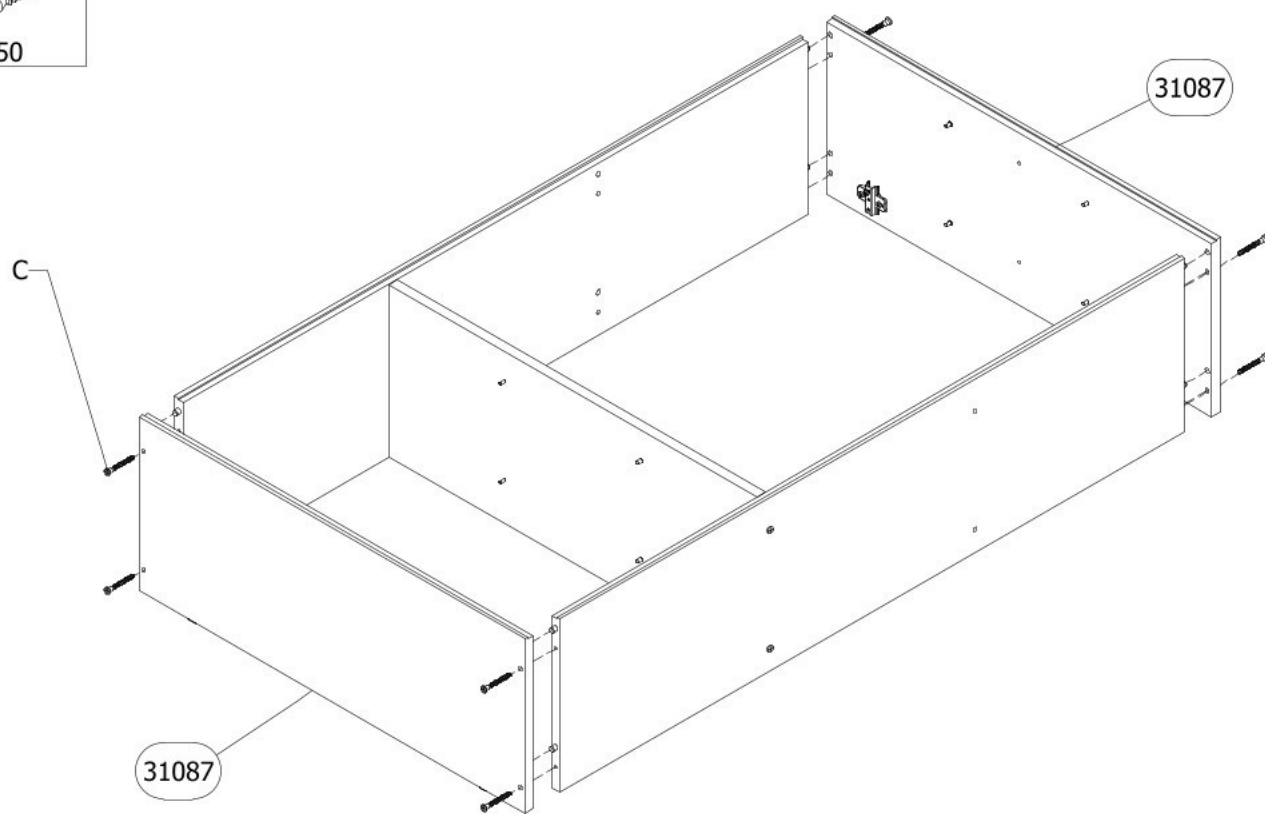

49

Ao x 1  
L=680mm

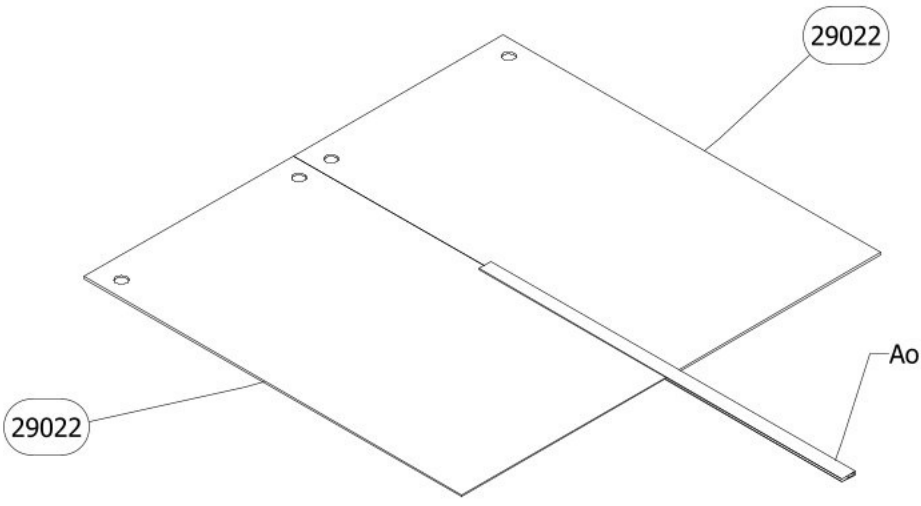

50

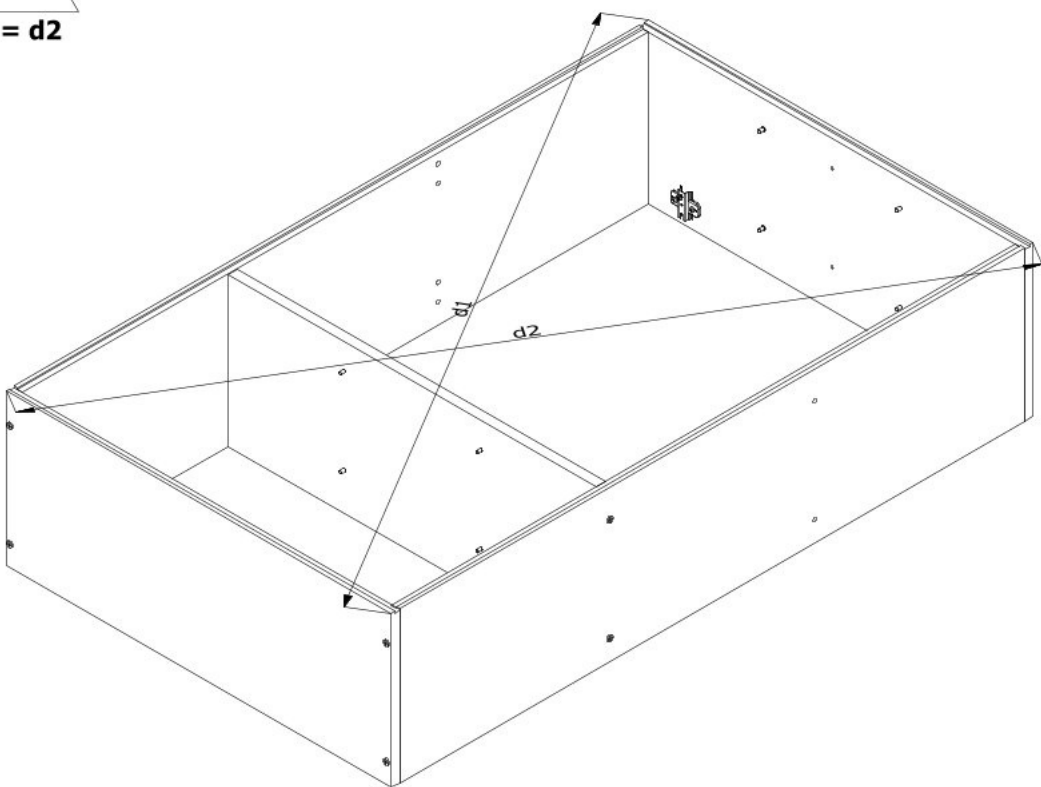

51	T x 3	U x 3	D x 32
		3x25	1.6 x 25

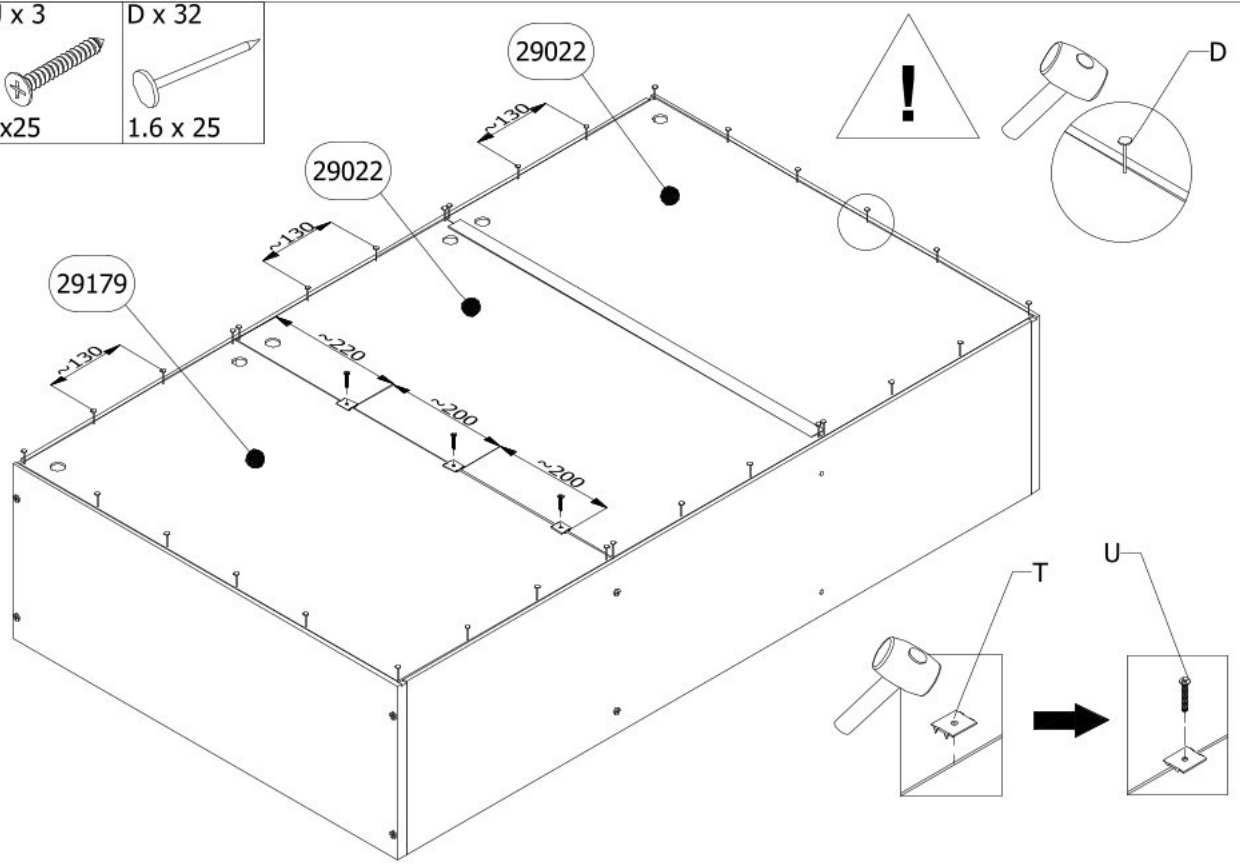

52	I x 2	J x 2	H x 8	S x 2	S3
		6x60	4x16		

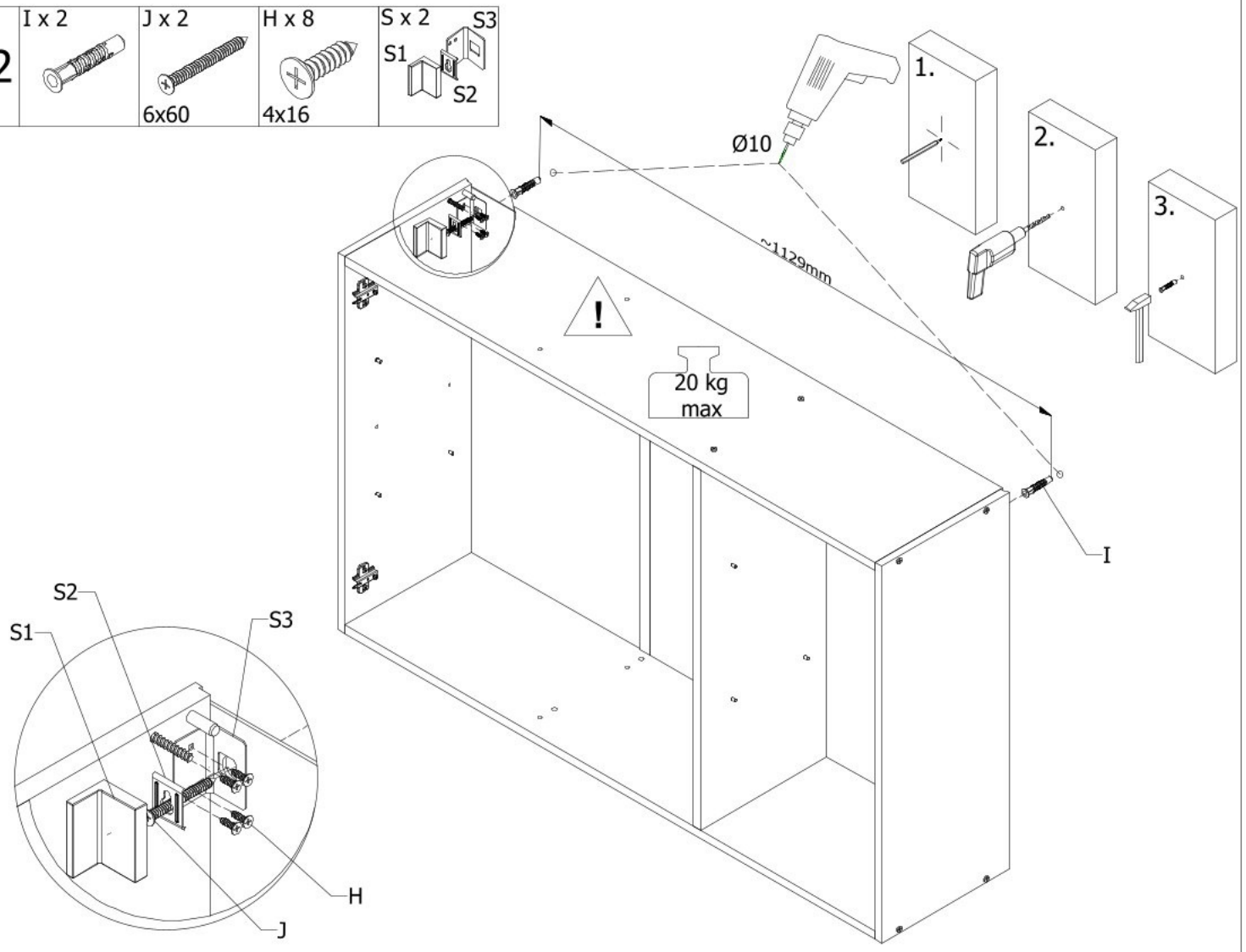

53

X x 6	Y x 4	N x 6
-------	-------	-------

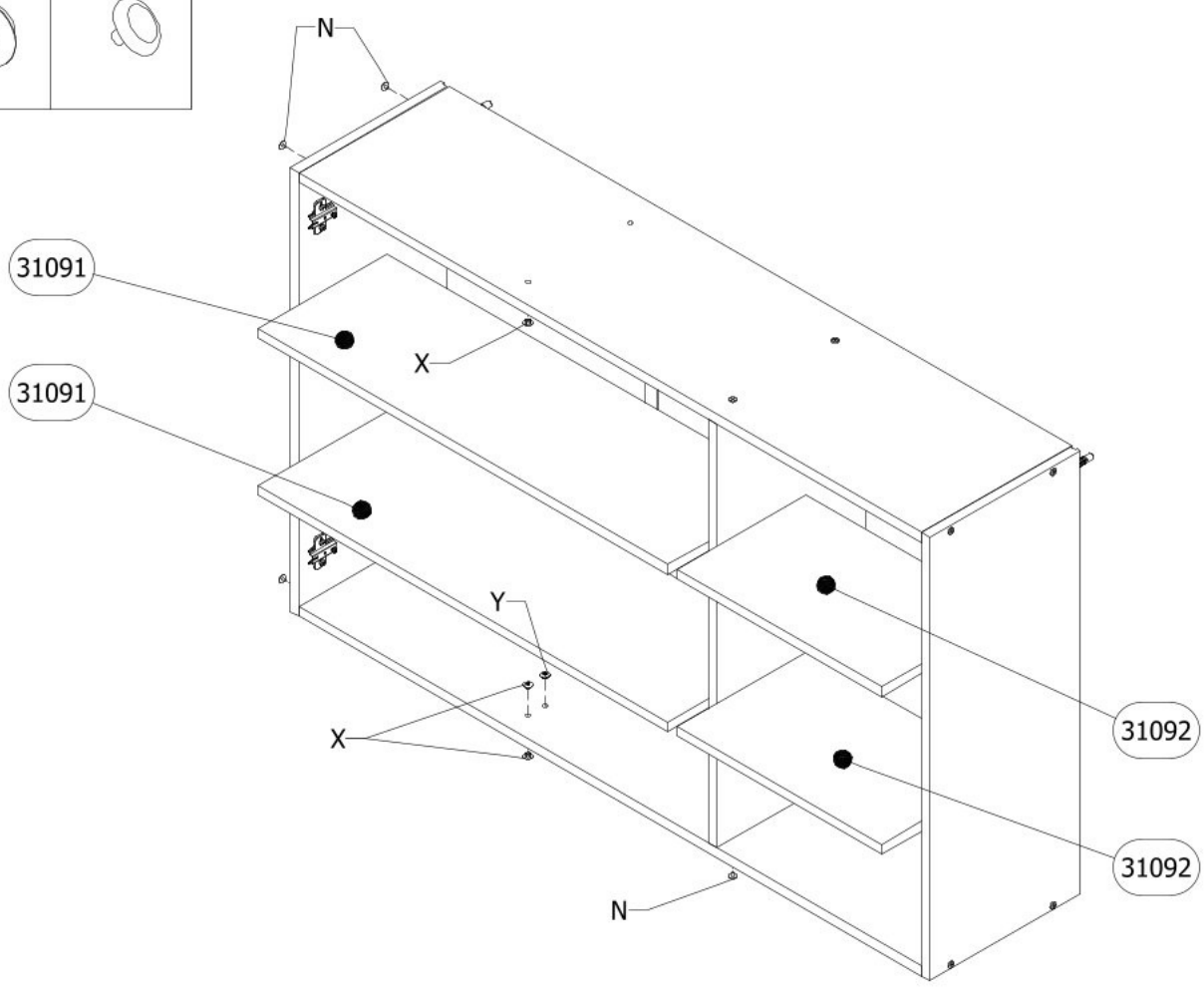

54

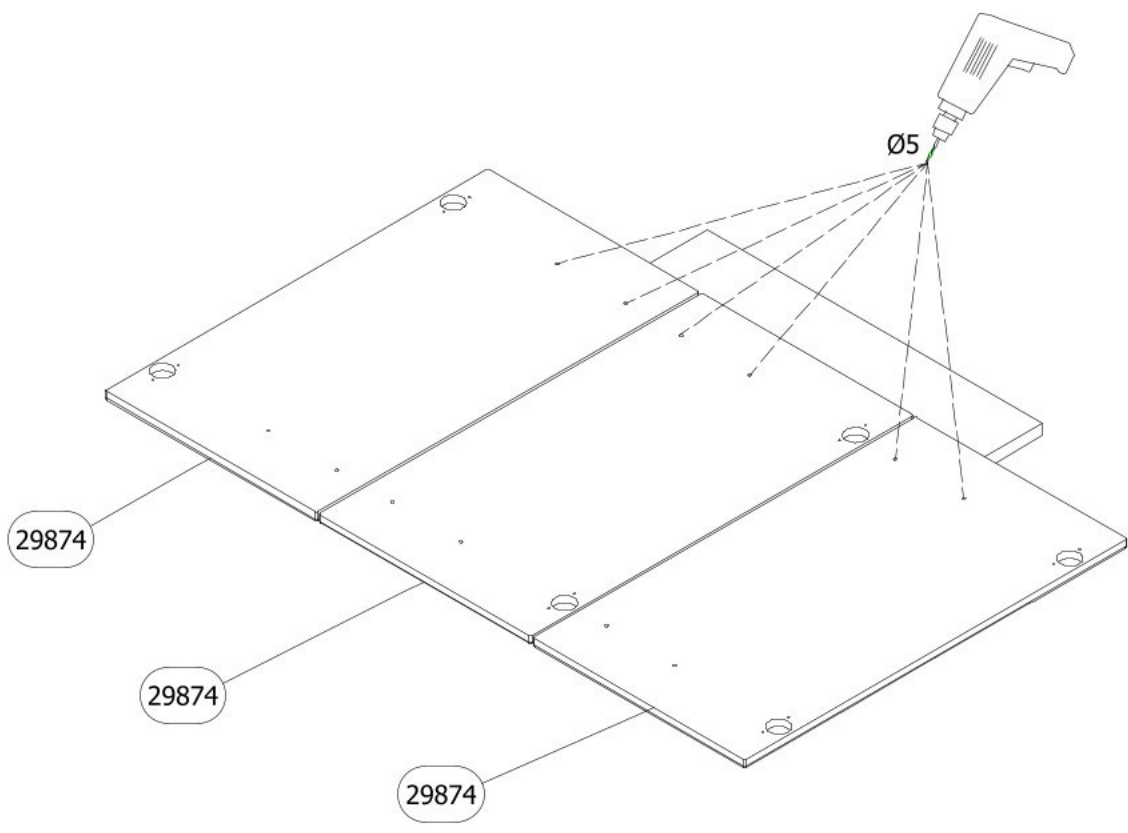

**55** V x 2 K x 2 L x 1  
M 4x25

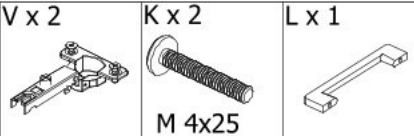
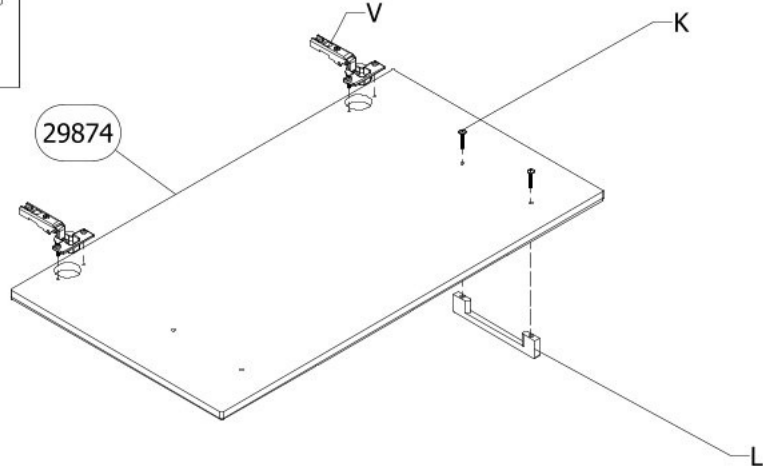
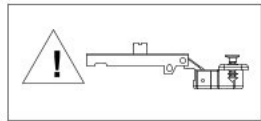
**56** V x 4 K x 4 L x 2  
M 4x25



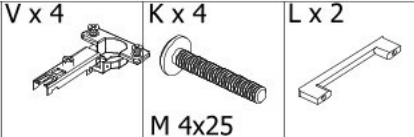
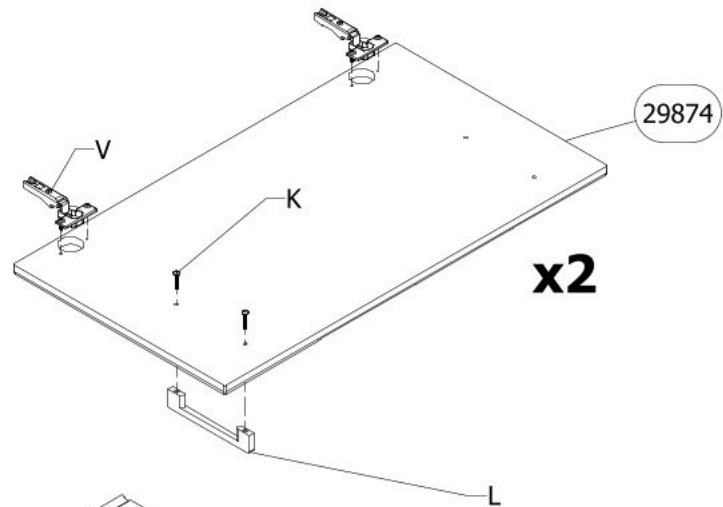
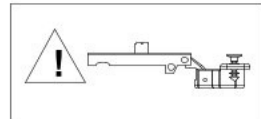

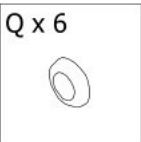
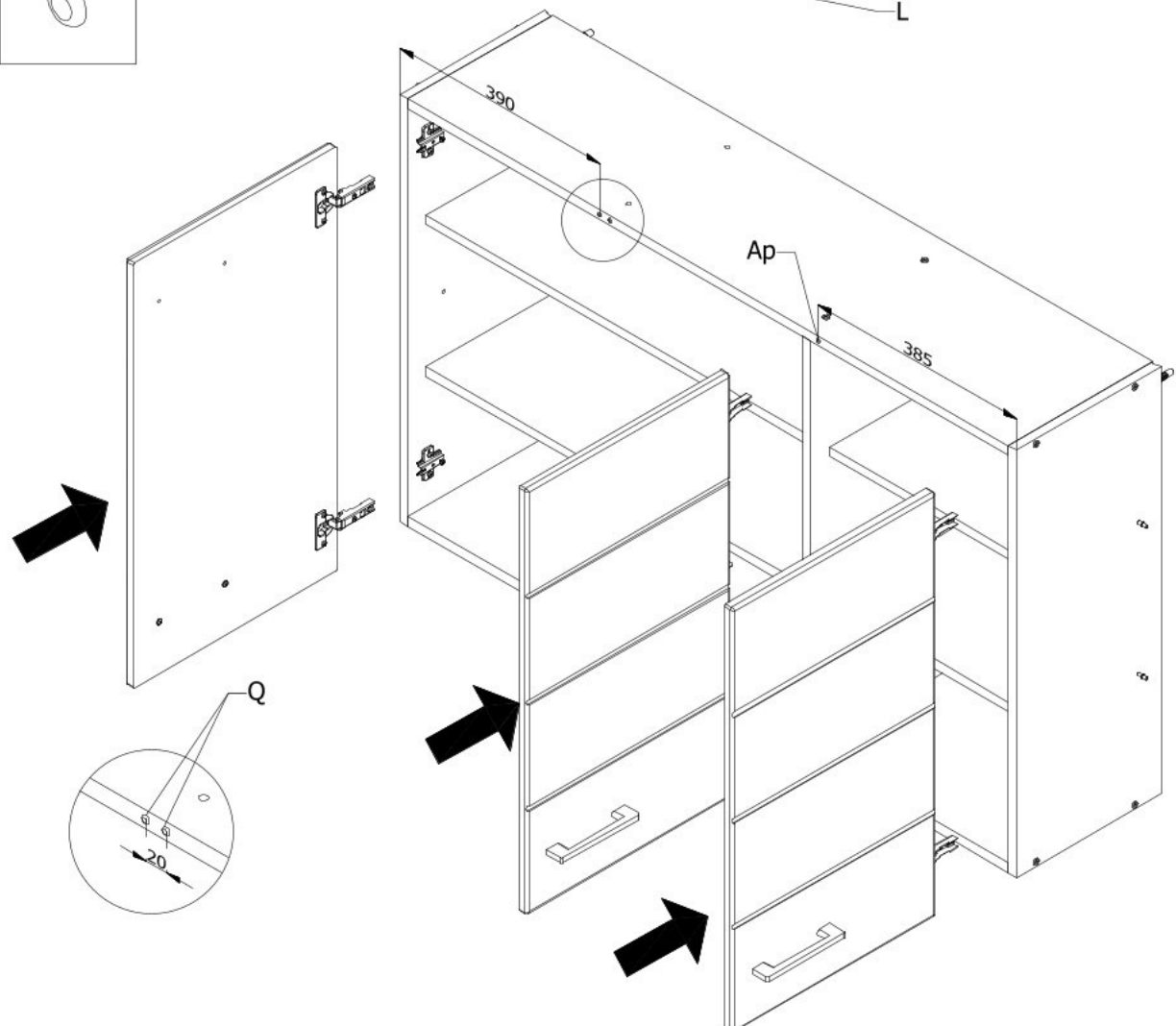

**57** Q x 6



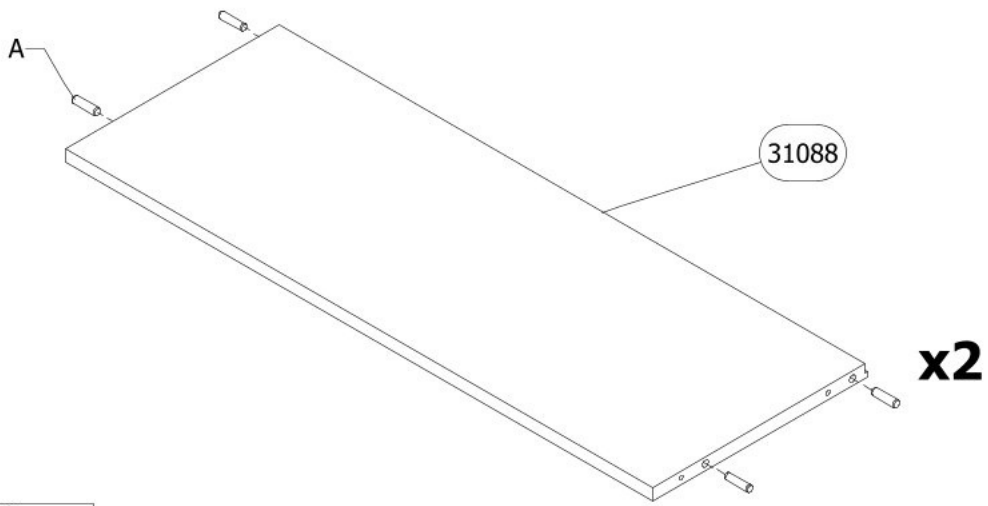



**58** A x 8  
  
 Ø8x30

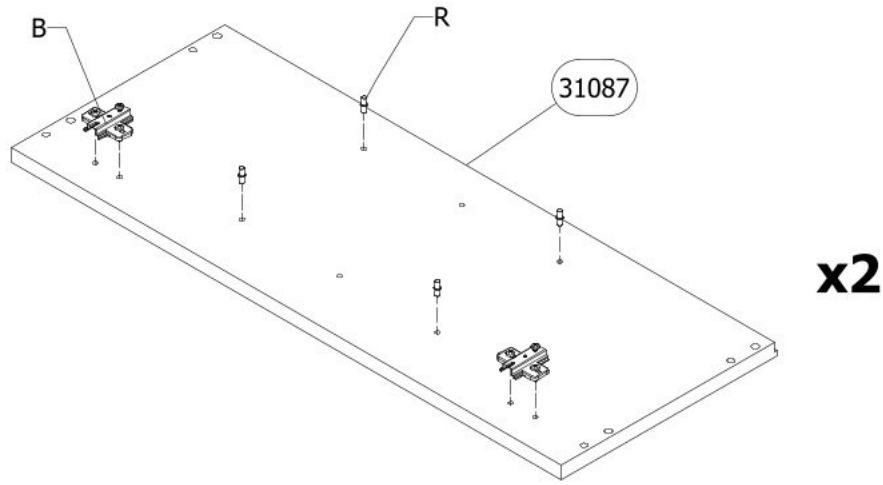

**59** B x 4 R x 8  
  



**60** C x 8  
  
 Ø7x50

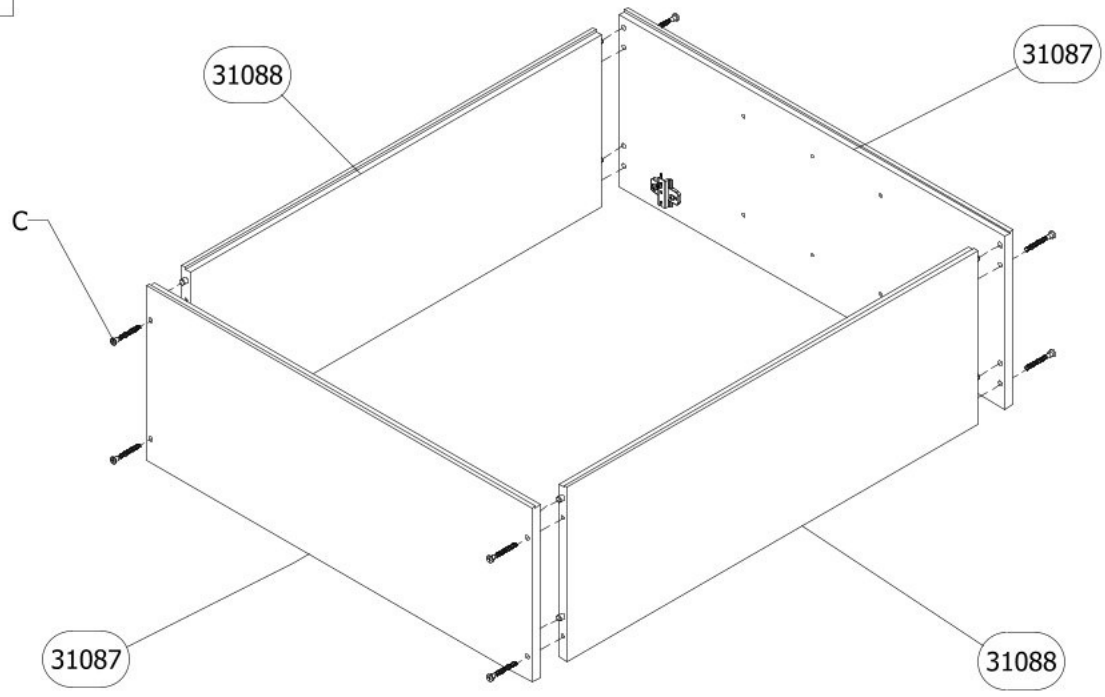

61

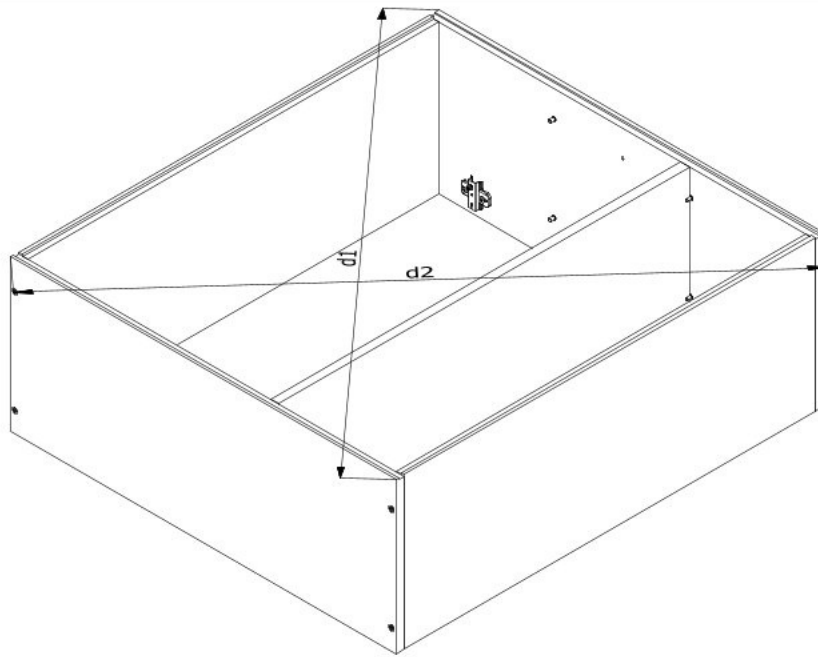

62

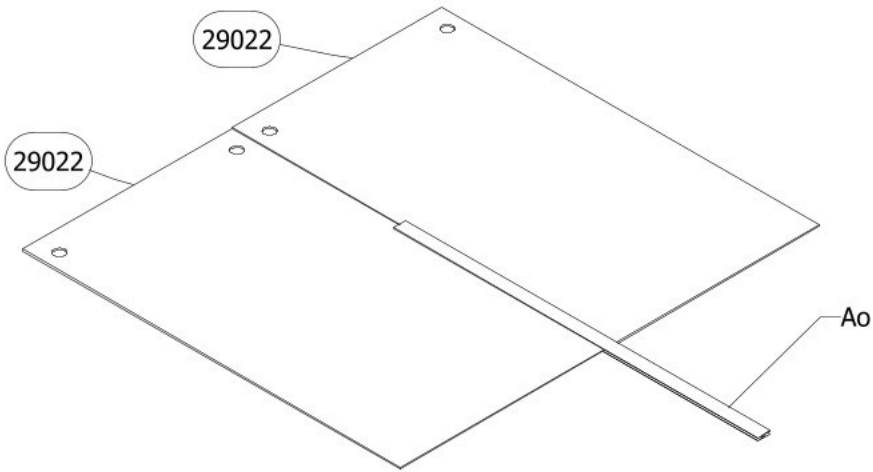
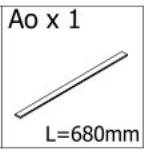



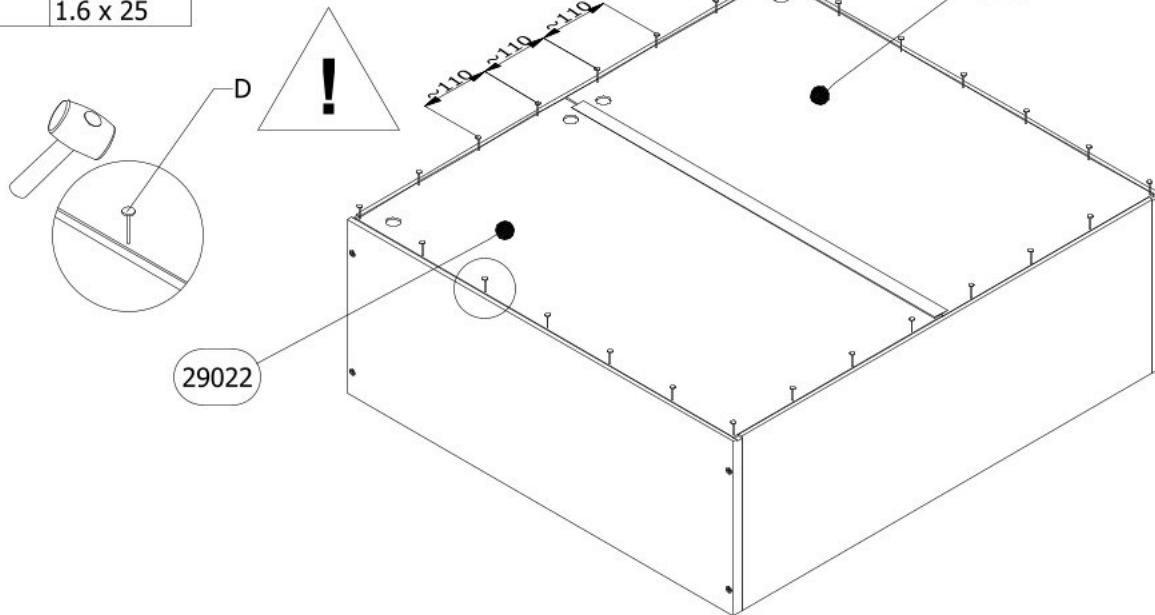
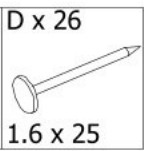

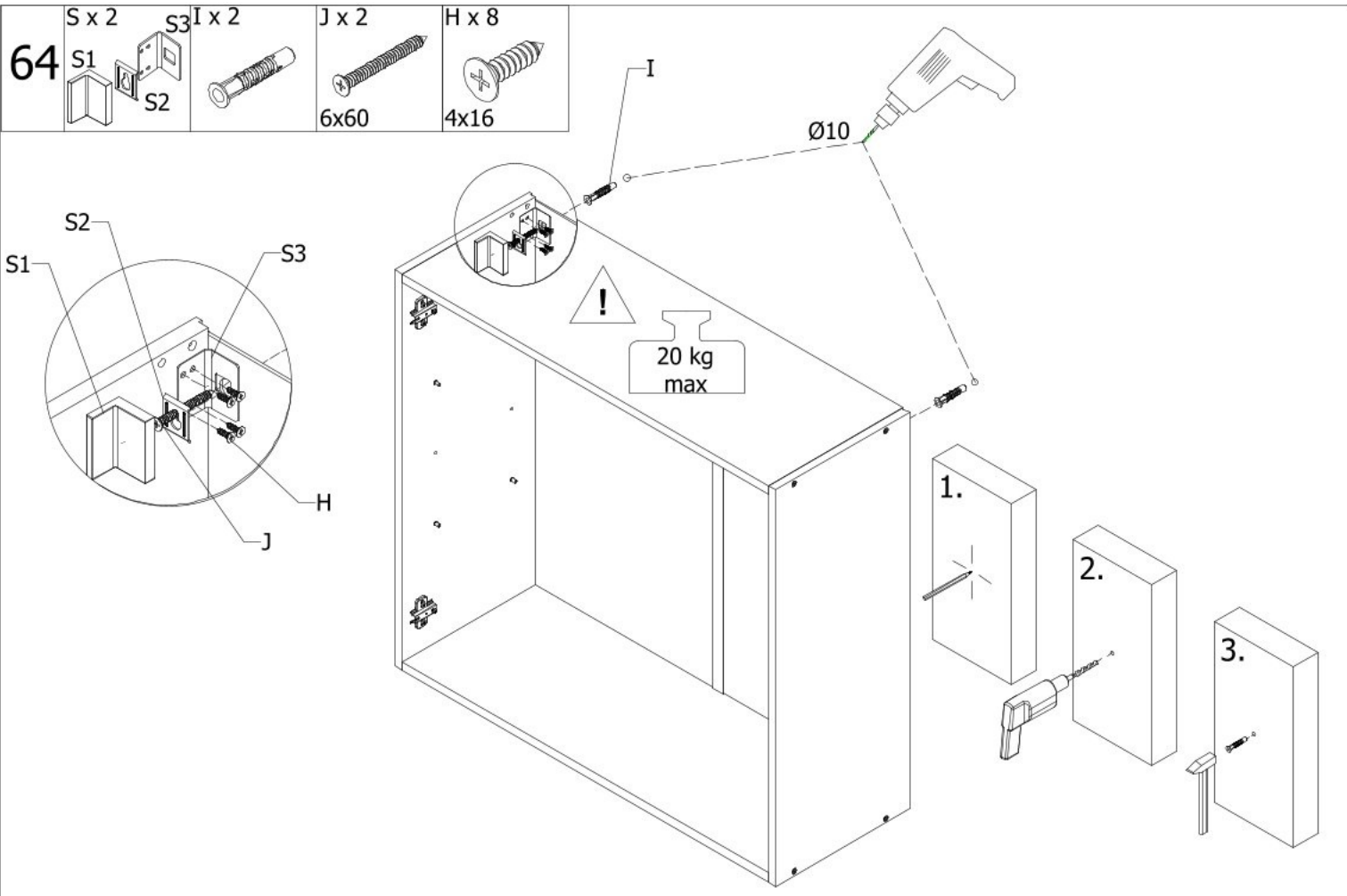

63

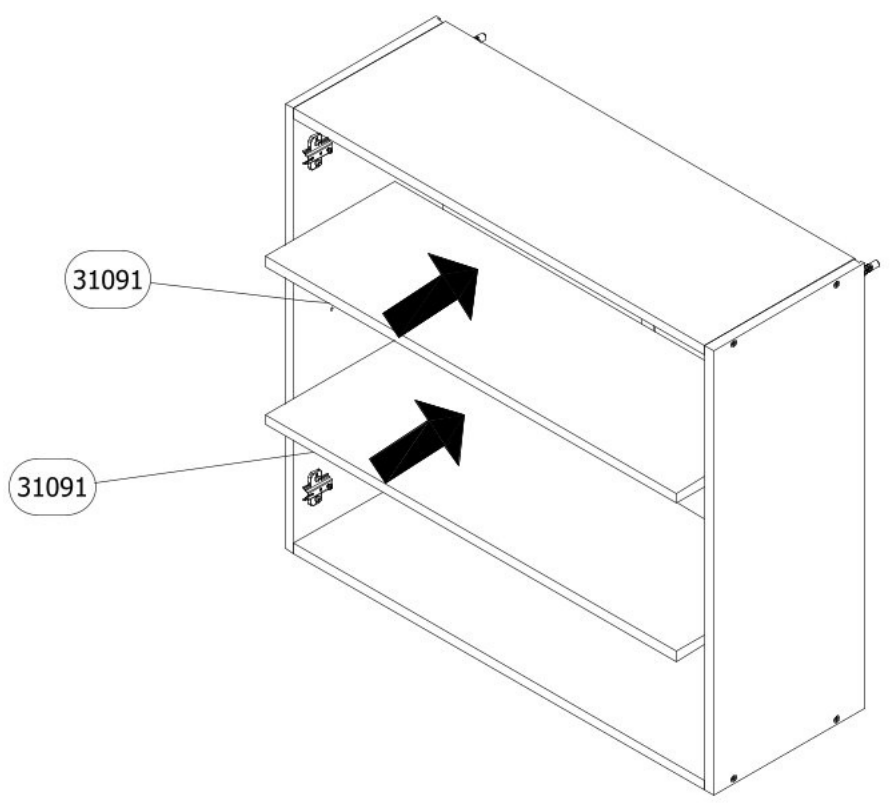







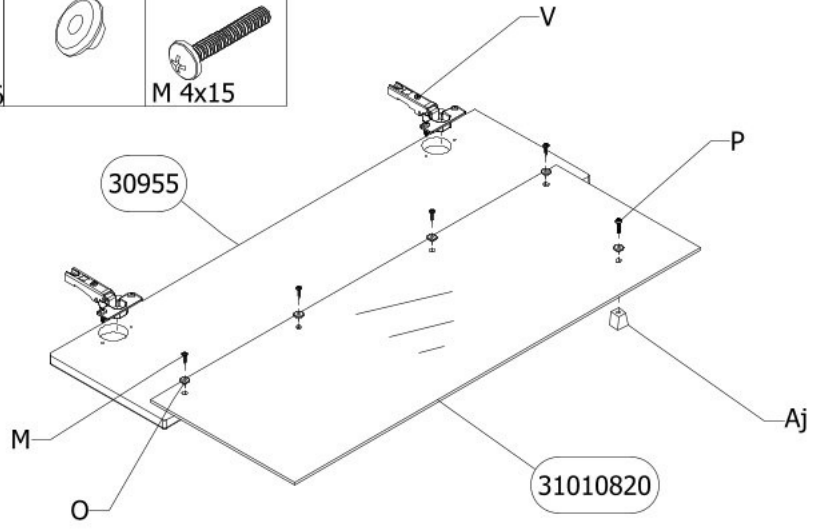

**65**





<b>66</b>	V x 2 	Aj x 1 	M x 4  4x16	O x 5 	P x 1  M 4x15
-----------	---	--	---	---	---

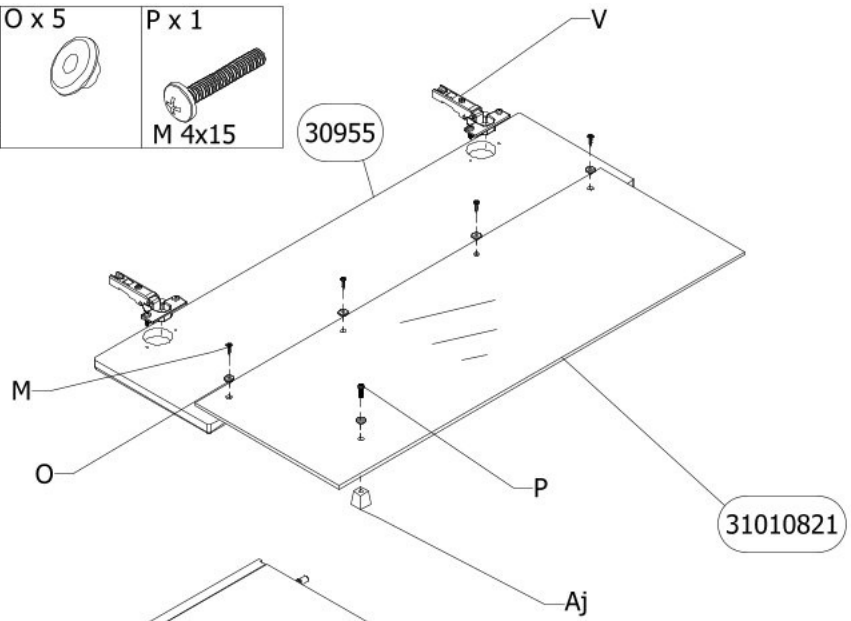

<b>67</b>	V x 2 	Aj x 1 	M x 4  4x16	O x 5 	P x 1  M 4x15
-----------	--	---	--	--	--



<b>68</b>	N x 4 	Q x 4 
-----------	--	--

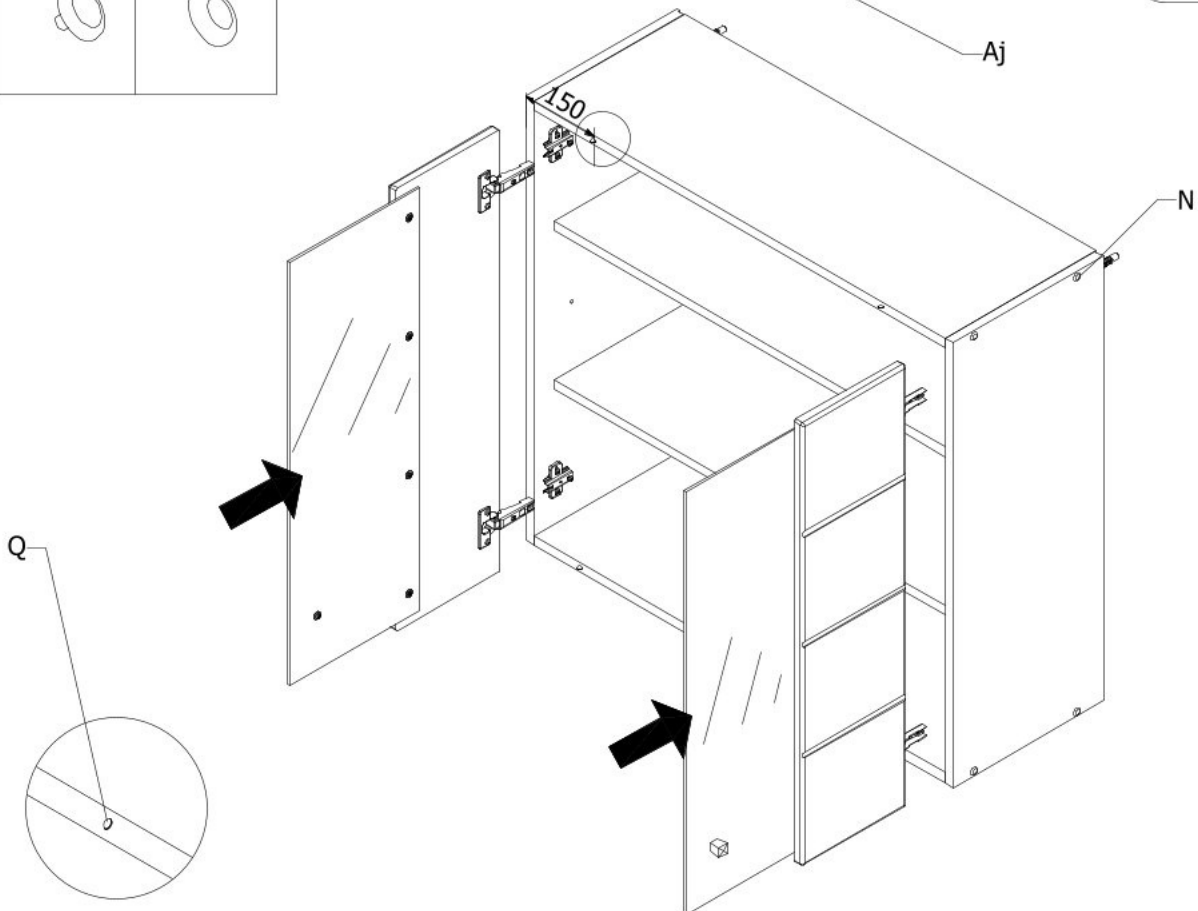

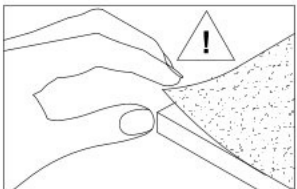
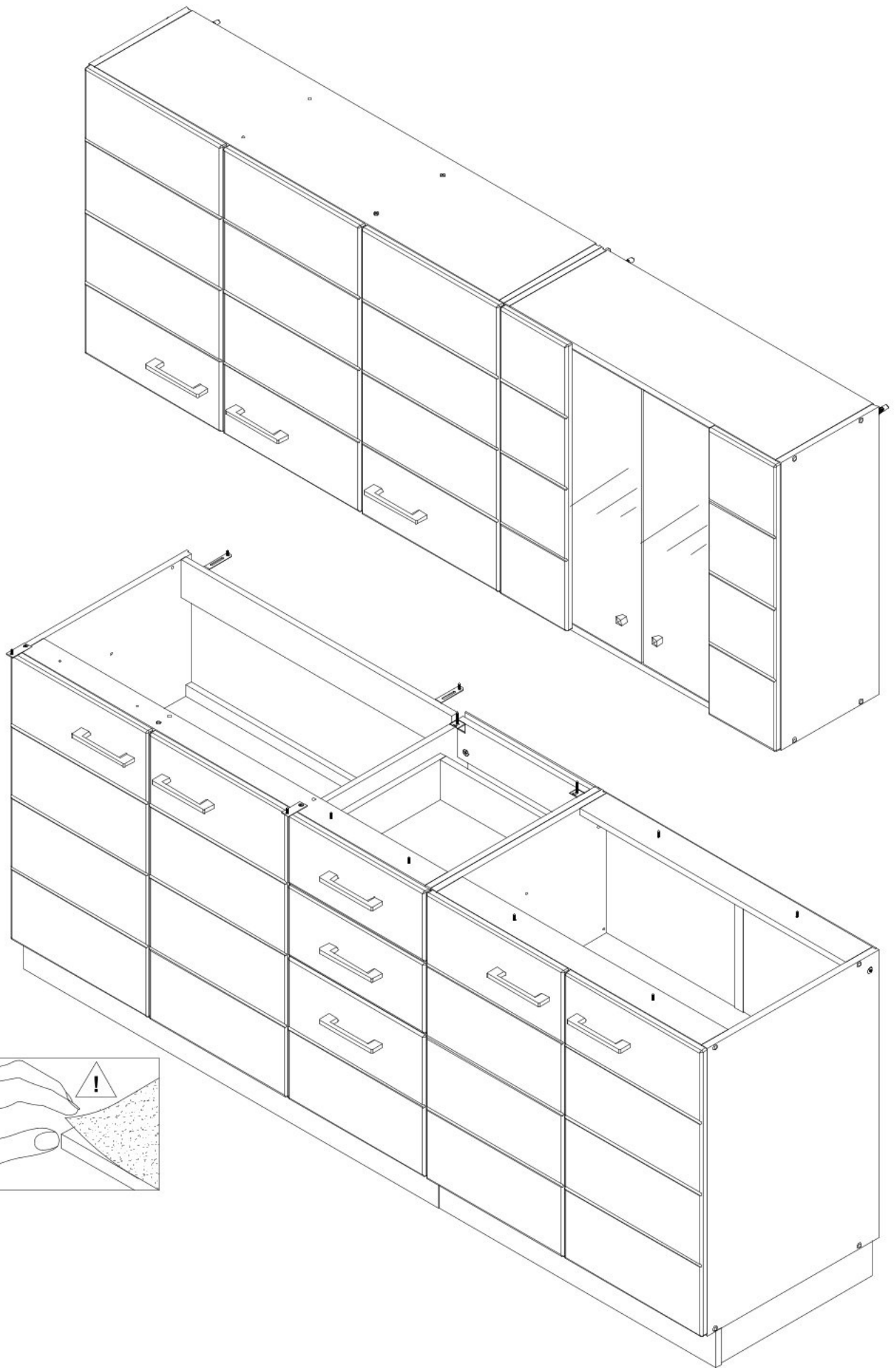

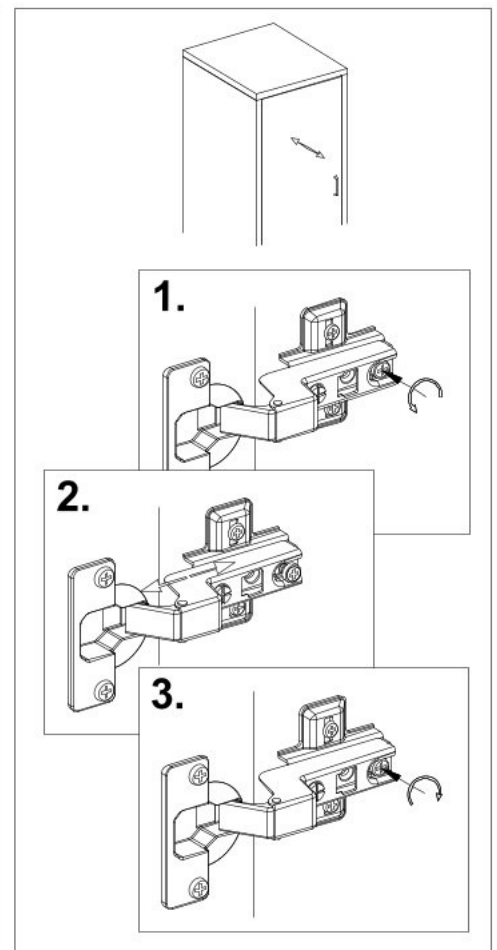
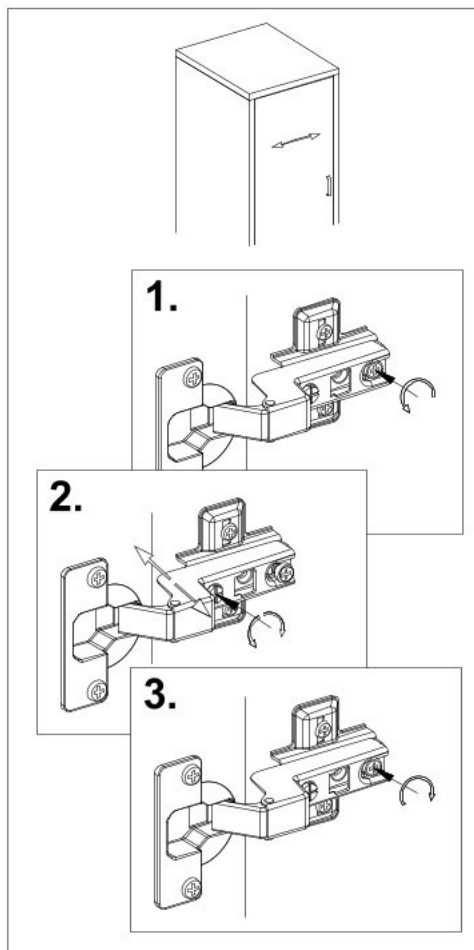
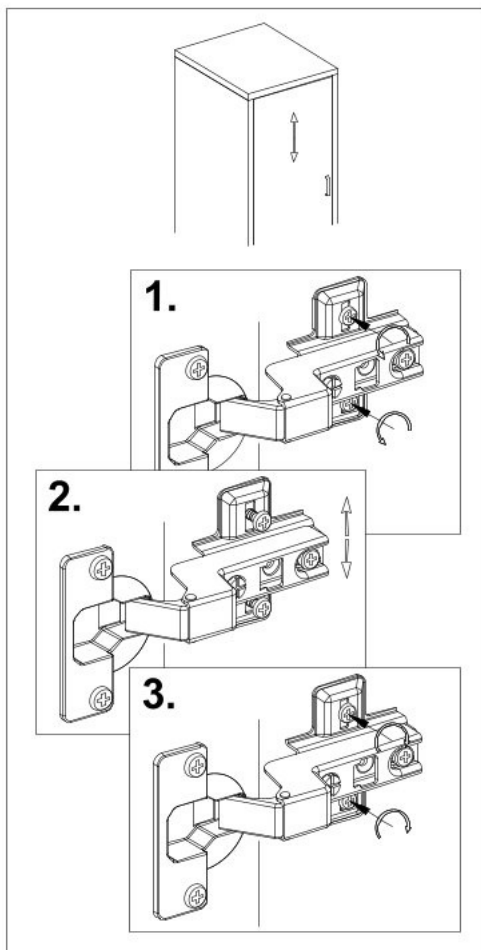
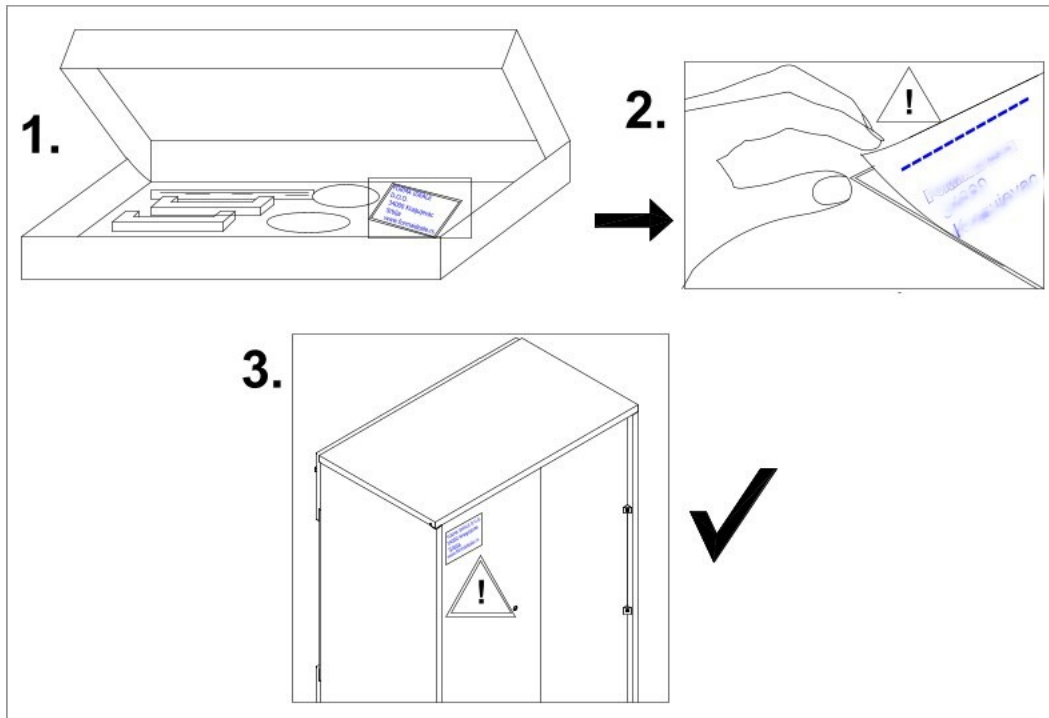



**RS ME - UPOZORENJE!** Poštovani kupci, kako bi izbegli moguće štete i povrede usled pada proizvoda, molimo Vas da se pridržavate uputstva za pričvršćivanje proizvoda za zid.  
**UK - ATTENTION!** Dear customers, in order to avoid possible damages and injuries due to the fall of the product, please observe the assembly instructions for fixing the products to the wall.  
**DE AT CH - KIPPSICHERUNG!** Sehr geehrte Kunden, um mögliche Schäden und Verletzungen durch den Fall des Produktes zu vermeiden, beachten Sie bitte die Montageanleitung zur Befestigung der Produkte an der Wand.

**CZ - UPOZORNĚNÍ!** Vážení kupci, abyste předešli možnému poškození a zranění v důsledku pádu výrobku, prosíme, dodržujte pokyny pro upevnění výrobku na zeď.

**ES - ATENCIÓN!** Estimados clientes, a fin de evitar posibles daños y lesiones debido a la caída del producto, le rogamos que siga las instrucciones para fijar el producto a la pared.

**RUS BLR - ВНИМАНИЕ!** Уважаемые покупатели, во избежание возможного ущерба и повреждения вследствие падения продукта просим Вас соблюдать инструкцию по приклеплению продуктов к стене.

**EL - ΠΡΟΣΟΧΗ!** Αξιότιμοι πελάτες, προκειμένου να αποφύγετε τυχόν ζημιές και τραυματισμούς από την πτώση του προϊόντος, σας παρακαλούμε να ακολουθήσετε τις οδηγίες για στερέωση του προϊόντος στον τοίχο.

**BG - ВНИМАНИЕ!** Уважаеми клиенти, за да избегнете евентуални повреди и наранявания, причинени от падането на продукта, спазвайте инструкциите за закрепване на продукта към стената.

**SL - POZOR!** Spoštovani kupci, da bi se izognili morebitnim škodam in poškodbam zaradi pada izdelka, vas prosimo, da upoštevate navodila za pritrditev izdelka na steno.

**МК - ВНИМАНИЕ!** Почитувани купувачи, за да ги избегнете можните штети и повреди предизвикани од пад на производот, Ве молиме да ги почитувате упатствата за прицврстување на производот на ѕид.

**PL - UWAGA!** Szanowni Klienci, w celu uniknięcia ewentualnych obrażeń ciała spowodowanych spadającymi przedmiotami, należy przestrzegać instrukcji mocowania produktu do ściany.

**IT - ATTENZIONE!** Gentili clienti, al fine di evitare eventuali danni o incidenti causati dalla caduta dei prodotti, siete pregati di seguire le istruzioni in merito alle modalità di affissione del prodotto sul muro.

**SK - POZOR!** Vážení zákazníci, aby ste predišli možnému poškodeniu a poraneniám v dôsledku spadnutia výrobku, dodržiavajte prosíme Vas pokyny na upevnenie výrobku na stenu.

**RO - ATENȚIE!** Dragi clienți, pentru a evita posibile pagube și vătămări datorită căderii produsului, vă rugăm să respectați instrucțiunile pentru fixarea produsului pe perete.

**HR BIH - OPREZI!** Poštovani kupci, kako bi se izbjegle moguće štete i ozljede uslijed pada proizvoda, pridržavajte se uputa za pričvršćivanje proizvoda na zid.

**HU - FIGYELEM!** Tisztelt vásárlók, a termék leesése következtében keletkezendő esetleges károk és sérülések elkerülése érdekében, kérjük, tartsák be a termék falra erősítésére szolgáló utasításokat.

**AL - KUJDES!** Klientë të dashur, me qëllim për të parandaluar dëmtime dhe lëndime të mundshme si pasojë e rënies së produktit, ju lutemi që të respektoni udhëzimet për fiksimin e produktit në mur.

**PT - ATENÇÃO!** Estimados clientes, Para evitar possíveis danos e ferimentos devido à queda do produto, siga as instruções para fixar o produto na parede.

**NL BE - WAARSCHUWING!** Geachte klanten om mogelijke schade en letsel als gevolg van het vallen van het product te voorkomen, volg de instructies voor het bevestigen van het product aan de muur



#### RS ME

Dostavljeni plastični tiplovi su namenjeni za ugradnju na standardan zid od cigle. Pre ugradnje korisnik je dužan da proveri da li dos tavljeni tiplovi odgovaraju vrsti zida na koji je predviđena ugradnja. Ukoliko tiplovi ne odgovaraju zidu kupac je u obavezi da u specijalizovanoj radnji sam nabavi odgovarajuće tiplove.

#### DE AT CH

Die gelieferten Plastikdübel sind zum Einbau in die standardmäßige Ziegelwand bestimmt. Vor dem Einbau ist der Benutzer verpflichtet zu prüfen, ob die gelieferten Dübel der für den Einbau vorgesehenen Wandart entsprechen. Wenn die Dübel der Wand nicht entsprechen, ist der Kunde verpflichtet, im Fachhandel entsprechende Dübel selbst zu besorgen.

#### ES

Las clavijas plásticas que se incluyen están previstas para ser insertadas en un muro de ladrillo estándar. Antes de instalarlas, el usuario debe verificar si las clavijas proporcionadas son adecuadas para el tipo de muro previsto en que se propone insertarlas. Si las clavijas no son adecuadas para el muro, el comprador debe adquirir por sí mismo las clavijas correspondientes en una tienda especializada.

#### RUS BLR

Входящие в комплект поставки пластиковые дюбели предназначены для монтажа на стандартную кирпичную стену. До начала монтажа пользователь должен проверить соответствие поставленных дюбелей типу стены, на которую предусмотрен монтаж. Если дюбели не соответствуют типу стены, покупатель должен в обязательном порядке приобрести соответствующие дюбели в специализированном магазине.

#### EL

Οι πλαστικές βύδες που παρέχονται προορίζονται για ενσωμάτωση σε συνθημαμένο τοίχο από τούβλα. Πριν από την ενσωμάτωση, ο χρήστης οφείλει να ελέγξει εάν οι βύδες που παρέχονται αντιστοιχούν στον τύπο του τοίχου στον οποίο προβλέπεται η ενσωμάτωση. Εάν οι βύδες δεν ταιριάζουν στον τοίχο, ο αγοραστής υποχρεούται να προμηθευθεί κατάλληλες σε εξειδικευμένο κατάστημα.

#### BG

Доставените пластмасови дюбели са направени за вграждане в стандартна тухлена стена. Преди вграждането, ползувателят е длъжен да провери дали доставените дюбели съответстват на стената, за която са предвидени за вграждане. Ако дюбелите не съответстват на стената на купувача, то той задължително трябва да закупи съответни дюбели от специализирания магазин.

#### SL

Dostavljeni plastični nosilci so namenjeni za montažo na standardni zid iz opeke. Pred montažo je uporabnik dolžan preveriti, ali dostavljeni nosilci ustrezajo vrsti zidu, na katerem je predvidena montaža. V kolikor nosilci niso primerni, je kupec dolžan sam pri specializiranemu prodajalcu priskrbiti nosilce, ki ustrezajo montaži.

#### МК

Доставените пластични типли наменети се за прикачување на стандарден ѕид од цигла. Пред прикачувањето корисникот е должен да провери дали доставените типли одговараат на ѕидот на кој е предвидено прикачувањето. Доколку типлите не одговараат купувачот е должен сам да набави во специјализирана продавница типли кои одговараат.

#### PL

Dołączone plastikowe kołki są przeznaczone do montażu na standardową ścianę z cegły. Przed zamontowaniem, użytkownik jest zobowiązany upewnić się, czy załączone kołki odpowiadają typowi ściany na której jest przewidziany montaż. W przypadku gdy kołki nie są odpowiednio do typu ściany, na którą ma być zamontowany regał, użytkownik jest zobowiązany, aby samemu zaopatrzyć się w odpowiedni typ kołków w sklepie specjalistycznym.

#### NL BE

Geleverde plastic pluggen zijn bedoeld voor montage op een standaard bakstenen muur. Voor montage dient de koper te controleren of de geleverde pluggen geschikt zijn voor de voorziene muur. Als de pluggen niet geschikt zijn voor de muur, moeten kopers een gespecialiseerde winkel bezoeken en zelf geschikte pluggen kopen.



#### UK

Delivered plastic plugs are intended for fitting on a standard brick wall. Before fitting, the buyer needs to check if the delivered plugs are suitable for the wall they are foreseen for. If the plugs are not suitable for the wall, buyers have to visit a specialized store and get suitable plugs by themselves.

#### IT CH

I tasselli di plastica consegnati sono destinati al montaggio su un muro di mattoni standard. Prima del loro montaggio, l'acquirente deve controllare se i tasselli forniti sono adatti per la parete su cui si prevede di installarli. Se i tasselli non sono adatti per questo tipo di parete, l'acquirente è tenuto ad acquistare i tasselli adeguati presso un negozio specializzato.

#### FR CH

Les chevilles en plastique fournies sont conçues à l'installation sur le mur standard en briques. Avant l'installation, l'utilisateur est obligé à vérifier si les chevilles fournies correspondent bien au type de mur prévu pour l'installation. Si les chevilles ne correspondent pas bien au mur, l'acheteur est obligé à assurer lui-même les chevilles correspondantes dans un magasin spécialisé.

#### CZ SK

Dodané plastové hmoždinky jsou určeny pro montáž na standardní cihlovou stěnu. Před začátkem montáže, kupující je povinen dohlédnout na správnost typu dodaných hmoždinek, vzhledem na typ stěny určené k montáži. Pokud hmoždinky dodané výrobcem neodpovídají typu stěny určené k montáži, kupující je povinen pořídit si správný typ ve specializované prodejně.

#### RO

Tiplurile din plastic transmise sunt prevăzute exclusiv pentru pereții standard din cărămidă. Înainte de instalare beneficiarul este obligat să verifice dacă tiplurile transmise corespund peretelui pe care se prevede instalarea. În cazul în care tiplurile nu corespund peretelui, cumpărătorul este obligat să achiziționeze singur tiplurile corespunzătoare din magazinele specializate.

#### HR BIH

Dostavljeni plastični tiplovi su namijenjeni za ugradnju na standardan zid od cigle. Prije ugradnje korisnik je dužan da li dostavljeni tiplovi odgovaraju vrsti zida na koji je predviđena ugradnja. Ukoliko tiplovi ne odgovaraju zidu kupac je u obavezi da u specijaliziranoj radnji sam nabavi odgovarajuće tiplove.

#### HU

A kézbesített műanyag tiplik standard téglafalra való beépítésre szolgálnak. Beépítés előtt a felhasználó köteles leellenőrizni, hogy a tiplik megfelelőek-e a falajtájának, amelyre a beépítést szánták. Ha a tiplik nem felelnek meg, a vásárló köteles a megfelelőket szaküzletben beszerezni.

#### AL

Ankorat e dhëna plastike janë të dizajnuara për instalim në mur standard me tulla. Para instalimit përdoruesi duhet të verifikojë nëse ankorat e dërguara iu përshtaten llojit të murit në të cilin është parashikuar të bëhet instalimi. Nëse ankorat nuk iu përshtaten murit, blerësi është i obliguar që vetë të blejë ankorat e duhura në shitoren e specializuar.

#### PT

As buchas plásticas fornecidas destinam-se à instalação numa parede de tijolos padrão. Antes da instalação, é obrigado a verificar se as buchas fornecidas correspondem ao tipo de parede em que instalação está prevista. Se as buchas não forem as mais indicadas à parede, será da responsabilidade do cliente a compra das buchas apropriadas em uma loja especializada.